

Excess flow check valves are designed to close upon excessive discharge of liquid or vapor resulting from a break in the piping system. When the flow rate exceeds the valve setting, the valve closes and remains closed until the system pressure equalizes. If the flow does not exceed the setting the valve will not close. Careful consideration should be given to valve selection.

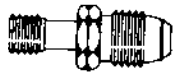

F173 Series

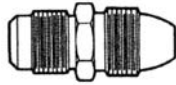

ME350 Series

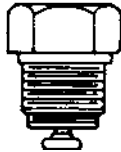

F100 Series



2884D

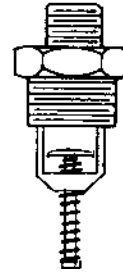

A8013 Series



2723 Series

Service	RMI Part No.	Inlet	Outlet	Construction	Liquid(GPM)	Vapor(SCFH 25 PSIG Inlet)	Vapor(SCFH 100 PSIG Inlet)
HOSE CONNECTION	F173	MPOL	1/4" MNPT	Brass	0.7	120	204
	F173A	Soft Nose MPOL	1/4" MNPT	Brass	0.7	120	204
	F181	MPOL	1/4" MNPT	Brass	1.5	335	570
	F110	MPOL	9/16"-18LH	Brass	0.7	120	204
	F110A	Soft Nose MPOL	9/16"-18LH	Brass	0.7	120	204
	F183	MPOL	9/16"-18LH	Brass	1.5	335	570
IN-LINE	F202	MPOL	1/2" FLARE	Brass	1.9	634	1100
	ME355EX18	MPOL	1/2" FLARE	Brass	1.8	Not Rated	Not Rated
	ME356EX18	MPOL	5/8" FLARE	Brass	1.8	Not Rated	Not Rated
	ME354EX18	MPOL	1/2" MNPT	Brass	1.8	Not Rated	Not Rated
	F138	1/4" MNPT	1/4" FNPT	Brass	1.8	377	641
	ME880-4/1.8	1/4" MNPT	1/4" FNPT	Brass	1.8	Not Rated	Not Rated
TANK & IN-LINE	ME880-6/4.6	3/4" MNPT	3/4" FNPT	Brass	4.6	Not Rated	Not Rated
	F170	3/4" MNPT	3/4" FNPT	Brass	6.6	1184	2012
	ME880S-6/4.6	3/4" MNPT	3/4" FNPT	Steel	4.6	Not Rated	Not Rated
	F100	3/4" MNPT	3/4" FNPT	Brass	8.4	2010	3417
	ME880-6/14	3/4" MNPT	3/4" FNPT	Steel	14	Not Rated	Not Rated
	ME880S-6/14	3/4" MNPT	3/4" FNPT	Steel	14	Not Rated	Not Rated
	ME880-6/17	3/4" MNPT	3/4" FNPT	Brass	17	Not Rated	Not Rated
	ME880S-6/17	3/4" MNPT	3/4" FNPT	Steel	17	Not Rated	Not Rated
	F101	3/4" MNPT	3/4" FNPT	Brass	20	3459	5880
	ME880-6/22	3/4" MNPT	3/4" FNPT	Brass	22	Not Rated	Not Rated
	ME880S-6/22	3/4" MNPT	3/4" FNPT	Steel	22	Not Rated	Not Rated
	ME880-6/28	3/4" MNPT	3/4" FNPT	Brass	28	Not Rated	Not Rated
	ME880S-6/28	3/4" MNPT	3/4" FNPT	Steel	28	Not Rated	Not Rated
	PRESSURE GAUGE	2884D	3/4" MNPT	1/4" FNPT	Brass	--	60
IN-LINE	41FFD	1" MNPT	1" MNPT x 1/2" FNPT	Steel	20	3400	5800
TANK	2723C	1 1/4" MNPT x 3/4" FNPT	3/4" MNPT	Brass	20	3900	6900
TANK & IN-LINE	ME880-10/32	1 1/4" MNPT	1 1/4" FNPT	Brass	32	Not Rated	Not Rated
	ME880S-10/32	1 1/4" MNPT	1 1/4" FNPT	Steel	32	Not Rated	Not Rated
	F102	1 1/4" MNPT	1 1/4" FNPT	Brass	33	6300	10630
	ME880-10/42	1 1/4" MNPT	1 1/4" FNPT	Brass	20	Not Rated	Not Rated
	ME880S-10/42	1 1/4" MNPT	1 1/4" FNPT	Steel	42	Not Rated	Not Rated
	F105	1 1/4" MNPT	1 1/4" FNPT	Brass	55	9982	16967
TANK	A8013D	1 1/4" MNPT	3/4" MNPT	Steel	39	8700	14700
	A8013DA	1 1/4" MNPT	1" MNPT	Steel	44	8700	14700
	A8013DB	1 1/4" MNPT	1 1/4" MNPT	Steel	55	10900	19300
	A8525	1 1/4" MNPT	1 1/4" MNPT	Steel	35	12540	21560
	7574	1 1/2" MNPT	1 1/2" FNPT	Brass	90	15200	28100
	ME880-16/80	2" MNPT	2" FNPT	Brass	80	Not Rated	Not Rated
	ME880S-16/80	2" MNPT	2" FNPT	Steel	80	Not Rated	Not Rated
	F106	2" MNPT	2" FNPT	Brass	85	18513	31467
	F107	2" MNPT	2" FNPT	Brass	100	20796	35349
	ME880-16/105	2" MNPT	2" FNPT	Brass	105	Not Rated	Not Rated
	ME880S-16/105	2" MNPT	2" FNPT	Steel	105	Not Rated	Not Rated
	ME880-16/114	2" MNPT	2" FNPT	Brass	114	Not Rated	Not Rated
	ME880S-16/114	2" MNPT	2" FNPT	Steel	114	Not Rated	Not Rated
	ME880S-24/265	3" MNPT	3" FNPT	Steel	265	Not Rated	Not Rated
	ME880S-24/350	3" MNPT	3" FNPT	Steel	350	Not Rated	Not Rated

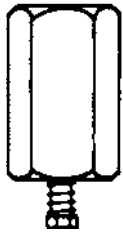

F130 & 1519 Series



F134 Series



F190 Series



2137, 2139 Series

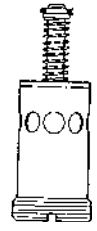

A3500 Series

Excess flow check valves are designed to close upon excessive discharge of liquid or vapor resulting from a break in the piping system. When the flow rate exceeds the valve setting, the valve closes and remains closed until the system pressure equalizes. If the flow does not exceed the setting the valve will not close. Careful consideration should be given to valve selection.

Service	RMI Part No.	Inlet	Outlet	Construction	Liquid, GPM	Vapor, SCFH 25 PSIG Inlet	Vapor, SCFH 100 PSIG Inlet
IN-LINE	F130	1" FNPT	1" FNPT	Brass	25	5,287	8,986
	A1519A2	1" FNPT	1" FNPT	Steel	25	5,000	8,800
	F131	1½" FNPT	1½" FNPT	Brass	60	11,694	19,877
	F132	2" FNPT	2" FNPT	Brass	95	19,874	33,877
	F133	2" FNPT	2" FNPT	Brass	155	29,202	49,718
	A1519A4	2" FNPT	2" FNPT	Steel	100	19,000	34,500
	A1519B4	2" FNPT	2" FNPT	Steel	133	27,700	50,300
	1519C4	2" FNPT	2" FNPT	Brass	170	28,590	48,600
TANK	F134	1½" MNPT x 1" FNPT	1" FNPT	Brass	28	5,181	8,806
	F135	2¼" MNPT x 1½" FNPT	1½" FNPT	Brass	60	12,000	20,290
	F190	2" MNPT	2" MNPT x 1¼" FNPT	Steel	80	15,400	26,250
	ME882S-16/80	2" MNPT	2" MNPT	Steel	80	Not Rated	Not Rated
	F191	2" MNPT	2" MNPT x 1¼" FNPT	Steel	105	18,800	32,000
	ME882S-16/105	2" MNPT	2" MNPT	Steel	105	Not Rated	Not Rated
	ME882S-16/114	2" MNPT	2" MNPT	Steel	114	Not Rated	Not Rated
	A7537P4F	2" MNPT	2" MNPT x 1¼" FNPT	Steel	150	30,500	52,000
	A2137	2" M x 1¼" F	2" M x 1¼" F	Steel	50	10,000	17,000
	A2137A	2" MNPT x 1¼" FNPT	2" MNPT x 1¼" FNPT	Steel	70	14,000	25,000
	A3500L4	2" MNPT	--	Steel	75	13,000	22,500
	A3500N4	2" MNPT	--	Steel	125	25,000	42,500
	A3500P4	2" MNPT	--	Steel	150	30,500	52,000
	40KI	3" MNPT	2" FNPT	Steel	172	--	--
	F194	3" MNPT	2" MNPT	Steel	165	32,800	55,950
	F195	3" MNPT	2" MNPT	Steel	260	50,650	86,350
	ME880S-24/265	3" MNPT	3" MNPT	Steel	265	Not Rated	Not Rated
	ME880S-24/350	3" MNPT	3" MNPT	Steel	350		
	F198	3" MNPT	3" MNPT x 2" FNPT	Steel	165	33,000	56,250
	ME882S-24/265	3" MNPT	3" MNPT x 2" FNPT	Steel	265	Not Rated	Not Rated
F199	3" MNPT	3" MNPT x 2" FNPT	Steel	260	49,500	84,350	
ME882S-24/350	3" MNPT	3" MNPT x 2" FNPT	Steel	350	Not Rated	Not Rated	
IN-LINE	A1519A6	3" FNPT	3" FNPT	Steel	225	45,000	82,000
	2139	3" M x 2" F	3" M x 2" F	Brass	125	26,500	46,000
	2139A	3" M x 2" F	3" M x 2" F	Brass	160	32,700	57,200
TANK	A3500R6	3" MNPT	--	Steel	150	32,100	55,500
	A3500T6	3" MNPT	--	Steel	200	39,400	68,300
	A3500V6	3" MNPT	--	Steel	250	51,100	88,700

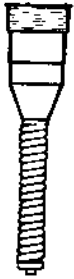

Fisher bobtail and transport stainless steel tank relief valves have low profile to reduce possible damage. New spring material more resistant to impurities.

H722-250



THREADED TRUCK RELIEF VALVES

RMI Part No.	Tank Connection	Relief Setting	Rain Cap	Installation Wrench	Type
H722-250	2"	250	P297	P304	Bobtail
H722-265	2"	265	P297	P304	Bobtail
H732-250	3"	250	P298	P305	Transport
H732-265	3"	265	P298	P305	Transport
H832N-3-265	3"	265	P298	P305	Transport



FLANGED RELIEF VALVES FOR TRANSPORTS

Flanged version of the H732 series valve.

- Leak free flanged tank connection
- Improved 300 series SS spring
- Also available with Kalrez, Neoprene and Viton O-rings.

RMI Part No.	Tank Connection	Relief Setting	Rain Cap
H732F-250	3" Flanged	250	P298
H732F-265	3" Flanged	250	P298

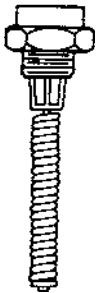

Sherwood internal relief valve for ASME bulk tanks 120-1000 WG. and new style DOT 420 lb. cylinder with separate relief valve.

443AM

DOMESTIC TANK RELIEF VALVES



RMI Part No.	Container Connection	Relief Setting	Rain Cap	Tank Capacity
445AM	1"	250	P206	ASME 100 Gal. Vert.
445AT	1"	375	P206	DOT 420 lb.
433AM	3/4"	250	433-45	ASME 120-320 WG
443AM	1"	250	443-45	ASME 500 WG
453AM	1 1/4"	250	453-45	ASME 1000 WG

STORAGE TANK RELIEF VALVES



H282



Fisher relief valves for bulk storage vessels 2,000 - 3,000 WG.

RMI Part No.	Tank Connection	Relief Setting	Construction	Rain Cap	Pipeaway Adaptor
H282-250	2"	250	Brass	AN11011	MEP104-24
H5112-250	2"	250	Stainless	AN11011	MEP104-24
H5112-265	2"	250	Stainless	AN11011	MEP104-24

BPS FLANGE MOUNT RELIEF VALVES ACF TYPE



3MBF-A Series

RMI Part No.	Description	Inlet Connection	Pipe-A-Way Thread	Flow Capacity
3MBF-A-250	Flange mount relief valve-250psig	3" Flange	3"FNPT	9347
3MBF-A-265	Flange mount relief valve-265psig	3" Flange	3"FNPT	9881
4MBF-A-250	Flange mount relief valve-250psig	4" Flange	3"FNPT	15452
4MBF-A-265	Flange mount relief valve-265psig	4" Flange	3"FNPT	16336

MARSHALL EXCELSIOR THREADED TRUCK RELIEF VALVES

- Designed for use in mobile LPG & NH3 containers
- Stainless Steel body construction
- Full internal construction



RMI Part No.	Tank Connection	Relief Setting	Seat Material	Service	Rain Cap	Installation Wrench
MEV200FIR/250	2"	250	Nitrile	LPG/NH3	MEV200FIR-09	MEP200FIR
MEV200FIR/265	2"	265	Nitrile	LPG/NH3	MEV200FIR-09	MEP200FIR
MEV200FIRV/250	2"	250	Viton	LPG	MEV200FIR-09	MEP200FIR
MEV200FIRV/265	2"	265	Viton	LPG	MEV200FIR-09	MEP200FIR
MEV200FIRK/250	2"	250	Kalrez	LPG/NH3	MEV200FIR-09	MEP200FIR
MEV200FIRK/265	2"	265	Kalrez	LPG/NH3	MEV200FIR-09	MEP200FIR
MEV300FIR/250	3"	250	Nitrile	LPG/NH3	MEV300FIR-09	MEP300FIR
MEV300FIR/265	3"	265	Nitrile	LPG/NH3	MEV300FIR-09	MEP300FIR
MEV300FIRV/250	3"	250	Viton	LPG	MEV300FIR-09	MEP300FIR
MEV300FIRV/265	3"	265	Viton	LPG	MEV300FIR-09	MEP300FIR
MEV300FIRK/250	3"	265	Kalrez	LPG/NH3	MEV300FIR-09	MEP300FIR
MEV300FIRK/265	3"	265	Kalrez	LPG/NH3	MEV300FIR-09	MEP300FIR

MARSHALL EXCELSIOR FLANGED RELIEF VALVES FOR TRANSPORTS/BOBTAILS

- Designed for use in mobile LPG & NH3 containers
- Flanged version of the MEV300FIR series valve
- Leak free flanged tank connection
- All stainless internal components



RMI Part No.	Tank Connection	Relief Setting	Seat Material	Service	Rain Cap
MEV300FIR-3F/250	3" 300#	250	Nitrile	LPG/NH3	MEV300FIR-09
MEV300FIR-3F/265	3" 300#	265	Nitrile	LPG/NH3	MEV300FIR-09
MEV300FIRV-3F/250	3" 300#	250	Viton	LPG	MEV300FIR-09
MEV300FIRV-3F/265	3" 300#	265	Viton	LPG	MEV300FIR-09
MEV300FIRK-3F/250	3" 300#	250	Kalrez	LPG/NH3	MEV300FIR-09
MEV300FIRK-3F/265	3" 300#	265	Kalrez	LPG/NH3	MEV300FIR-09

MARSHALL EXCELSIOR BULK STORAGE TANK RELIEF VALVES

- Designed for use in large stationary containers
- Steel and Stainless Steel internal components
- Stainless steel body for NH3 applications
- Also available with Nitrile, Viton or Kalrez seats



RMI Part No.	Tank Connection	Relief Setting	Construction	Rain Cap	Pipeaway Adaptor
MEV200SIR/250	2"	250	Brass	MEV200SIR-106	MEP104-24
MEV200SIR/265	2"	265	Brass	MEV200SIR-106	MEP104-24
MEV200SSIR/250	2"	250	Stainless	MEV200SIR-106	MEP104-24
MEV200SSIR/265	2"	265	Stainless	MEV200SIR-106	MEP104-24

MARSHALL EXCELSIOR QUAD-PORT RELIEF VALVE MANIFOLD

- Designed for large bulk storage containers with flanged relief openings
- Durable Teflon packing stem seals
- Valves have integral breakaway groove
- Stocked models are for LPG service., NH3 service (Nitrile) available.

RMI Part No.	Flange Size	Relief Setting	Service	Bolt Kit
ME904S-3F/250	3" 300#	250	LPG	ME904SK
ME904S-4F/250	4" 300#	250	LPG	ME904SK

Replacement Valves

RMI Part No.	Thread Size	Relief Setting	Service
MEV250/250VM	2 1/2"	250	UL
A3149G	2 1/2"	250	ASME/UL
MEP250	Installation Tool		
MEP170	2" x 2 1/2" Threaded Adapter		

© Ray Murray Inc. Edition 11

HYDROSTATIC RELIEF

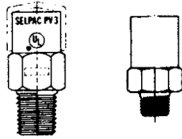

VALVES

- Small motor fuel
- Bulk plant liquid lines
- Bobtail trucks

RMI Part No.	Thread Size	Relief Setting	Material	Pipeaway Adaptor	Rain Cap
3865	1/4"	400psi	Brass	-	P205
MEH225SS/400	1/4"	400psi	Stainless	-	MEH501-.437
MEH225	1/4"	440psi	Brass	-	MEH501-.437
MEH225SS/440	1/4"	440psi	Stainless	-	MEH501-.437
H124	1/4"	450psi	Brass	-	P205
MEH25/450	1/4"	450psi	Brass	MEP173	MEH501-.812
H144	1/2"	450psi	Brass	P174	P206
MEH50/460	1/2"	460psi	Brass	MEP174	MEH501-1.062
H174	3/4"	450psi	Brass	P174	P206
MEH75/460	3/4"	460psi	Brass	MEP174	MEH501-1.062

Pipe-away thread size MEP173 1/4" P174 and MEP174 1/2"

EXTERNAL RELIEF VALVES

- DOT Cylinders
- ASME Tanks

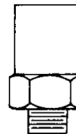
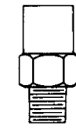

RMI Part No.	Thread Size	Relief Setting	Pipe-away	Rain Cap
H120-30	1/4"	30psi	-	P206
MEV25/60	1/4"	60psi	MEP173	MEH501-.812
H110-250	1/4"	250psi	-	P206
MEV25/250	1/4"	250psi	MEP173	MEH501-.812
MEV25/312	1/4"	312psi	MEP173	MEH501-.812
H123	1/4"	375psi	-	P206
MEV25/375	1/4"	375psi	MEP173	MEH501-.812
H125-250	1/2"	250psi	P174	P206
MEV50/250	1/2"	250psi	MEP174	MEH501-1.062
H148	1/2"	375psi	P174	P206
MEV50/375	1/2"	375psi	MEP174	MEH501-1.062
H185-250	3/4"	250psi	-	P145
MEV75/250	3/4"	250psi	MEP174	MEH501-1.062
MEV75/312	3/4"	312psi	MEP174	MEH501-1.062
H173	3/4"	375psi	P174	P206
MEV75/375	3/4"	375psi	MEP174	MEH501-1.062

Pipe-Away thread size MEP173 1/4" P174 and MEP174 1/2"

REGO RELIEF VALVES

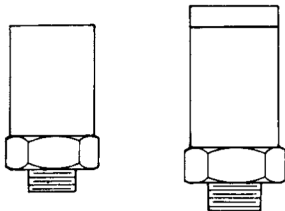

- Underground Tanks
- ASME style tanks
- Multi-port replacements

Relief Valve RMI Part No.	Thread Size	Relief Setting	RMI Part No.		Application
			Pipe-away	Rain Cap	
MV3132G	1/4"	250 lb	--	3132-54	G8475W Multivalve
M3131G	3/4"	250 lb	--	3131-54	G8475V Multivalve
AA3130UA250	3/4"	250 lb	AA3131-10	AA3130-40	Anhydrous Ammonia
AA3135UA250	1/4"	250 lb	AA3135-10	AA3135-40	Anhydrous Ammonia
W3132G	1"	250 lb	3131-10	3132-54	ASME Tanks
3132G	1/4"	250 lb	3132-10	3132-54	ASME Tanks
3135G	1/4"	250 lb	3135-10	3135-54	Lg. ASME Tanks
3133G	1/2"	250 lb	3135-10	3133-54	ASME Tanks
A3149MG	2 1/2"	250 lb	3" Pipe	3149-40	Rego Multi-port

UNIVERSAL RAIN CAP



85

Fits all standard relief valves. Has new sealed elastomer band with ozone and ultra-violet inhibitors. Fits tightly to protect valve from foreign material.

RMI Part No.	Description
85XXXX	Fits up to 3/4" Valve
85AXXX	Fits 1" and Larger

ANTHES WEATHER CAP

Economical steel cap closes tightly due to high hinge & counter balance. Stainless steel bushing & case hardened bolt protect against rust.



RMI Part No.	Pipe Size	Cap No.
AN11001	3/4"	#0
AN11002	1"	#1
AN11003	1 1/4"	#2
AN11004	1 1/2"	#3
AN11006	2"	#5
AN11007	2 1/2"	#6
AN11011	3"	#10
AN11015	4"	#14

PLASTIGAGE WEATHER CAP

Sturdy aluminum base and tough, durable plastic cover resists corrosion for long life. Includes "Heli-Coil" Spring.



RMI Part No.	Pipe Size
HWC0100	1"
HWC0200	2"
HWC0300	3"
HCW0400	4"

PIPE AWAY ADAPTOR

Breakoff groove protects relief valve.



MEP104-24

RMI Part No.	Size
MEP104-24	3" FNPT

FISHER

FISHER GLOBE AND ANGLE VALVES

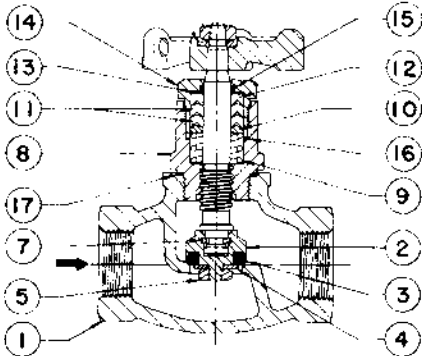

Valve No.	Size	RMI Part No.	
		Repair Kit Key #'s 3, 10, 11, 12, 15, 17	Complete Bonnet, Stem Seals & Seat Ass'y. Key #'s 2-17
N350, N450	1/2", 3/4"	RN350T00012	--
N301, N401	1/2", 3/4", 1"	RN30008T012	T12690T0012
N310, N410	1 1/4", 1 1/2"	RN30012T012	T20838T0012
N310, N410	2"	RN30016T012	T20818T0012
N310, N410	3"	RN30024T012	T40259T0012

FISHER

FISHER INTERNAL VALVE REPLACEMENT PARTS KITS

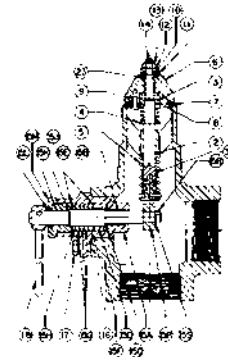

Valve No.	Size	RMI Part No.	
		Complete Repair Kit	Packing Gland Repair Kit
C421, C427	2" NPT	RC40016T012	T20377000A2
C421, C427	3" NPT	RC40024T012	T20430000A2
C404-43	4" Flange	RC20443T012	T11396000A2
C403-24	3" Flange	RC40324T012	--
C404-24	3" Flange	RC40424T012	--
C407-10	1 1/4" NPT	RC40710T012	--
C208	1 1/4" NPT	RC208T00012	--

JOMAR 500 SERIES BOLTED

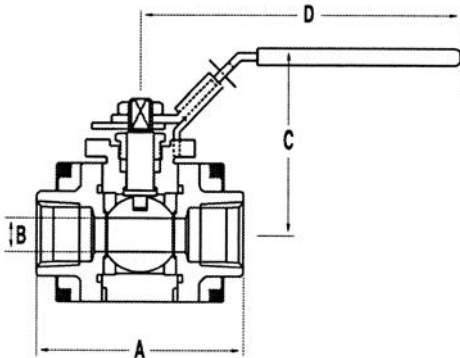

Valve Size	Valve Part No.	RMI Part No.	
		Repair Kit	SW End
1/4"	500-301	899-911	N/A
3/8"	500-302	899-912	N/A
1/2"	500-303	899-913	500-323
3/4"	500-304	899-914	500-324
1"	500-305	899-915	500-325
1 1/4"	500-306	899-916	500-326
1 1/2"	500-307	899-917	500-327
2"	500-308	899-918	500-328
3"	500-310	899-920	500-330
4"	500-311	899-9211	500-331

JOMAR 600 SERIES FLANGED

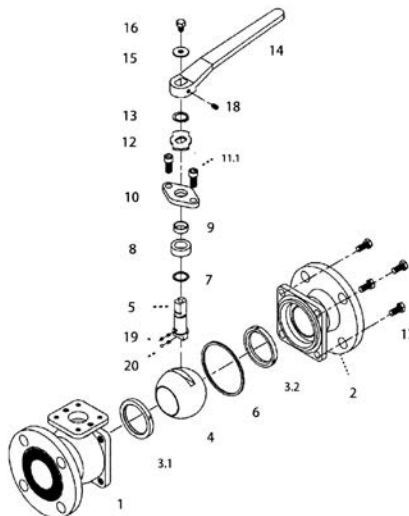

Valve Size	Valve Part No.	RMI Part No.
		Repair Kit
2"	600-228	600-136
3"	600-230	600-138
4"	600-231	600-139

JOMAR UNION END

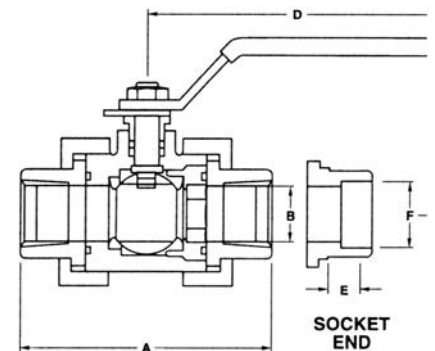

Valve Size	Valve Part No.	RMI Part No.	
		Repair Kit	SW End
1/4"	100-981	899-981	100-981SWE
3/8"	100-982	899-982	100-982SWE
1/2"	100-983	899-983	100-983SWE
3/4"	100-984	899-984	100-984SWE
1"	100-985	899-985	100-985SWE
1 1/4"	100-986	899-986	100-986SWE
1 1/2"	100-987	899-987	100-987SWE
2"	100-988	899-988	100-988SWE

© Ray Murray Inc. Edition 11

REPAIR PARTS FOR MARPAC BALL VALVES

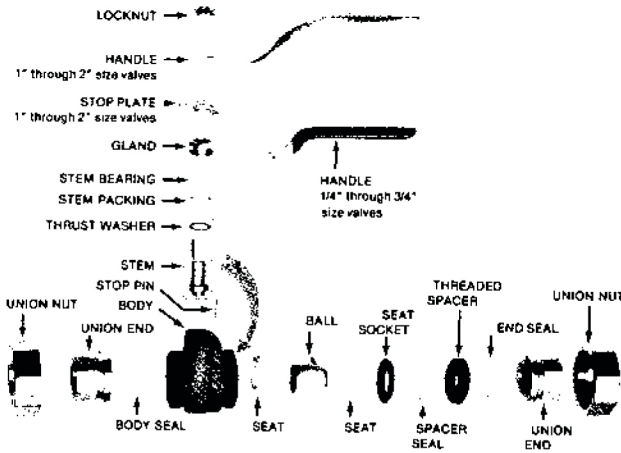

B790 & DI-800 KITS

RMI Part No.			
Valve	Old Style Valve	Service Kit	Size
B790-TT	CS-790TT	5807-ATT	1/4" - 1/2"
B790-TT	CS-790TT	5807-DTT	3/4"
B790-TT	CS-790TT	5807-ETT	1"
B790-TT	CS-790TT	5807-FTT	1 1/4"
B790-TT	CS-790TT	5807-GTT	1 1/2"
B790-TT	CS-790TT	5807-HTT	2"
DI-800-TT	--	9109-KIT	3"

B790 Kit Includes: 1 stem bearing, 1 thrust washer, 1 stem packing, 1 spacer seal, 2 seats, 1 body seal, and 1 end seal.

DI-800 Kit Includes: 1 thrust washer, 1 stem packing set, 2 end seals, & 2 seats.

CSE790 & CSEFP3 KITS

RMI Part No.		
New Style Valve	Service Kit	Size
CSE-790TTU	5807-EATT	1/4" - 1/2"
CSE-790TTU	5807-EDTT	3/4"
CSE-790TTU	5807-EETT	1"
CSE-790TTU	5807-EFTT	1 1/4"
CSE-790TTU	5807-EGTT	1 1/2"
CSE-790TTU	5807-EHTT	2"
CSEFP3-12TT	5826-HTT	2" Flanged
CSEFP3-12TT	5826-KTT	3" Flanged
CSEFP3-12TT	5826-LTT	4" Flanged

CSE790 Kit Includes: 1 stem seal set, 1 spacer seal, 2 seats, 1 body seal, and 1 grounding washer.

CSEFP3 Kit Includes: 2 seats, 1 stem seal, 1 body seal, 1 grounding washer.

APOLLO FLANGED REPAIR KITS

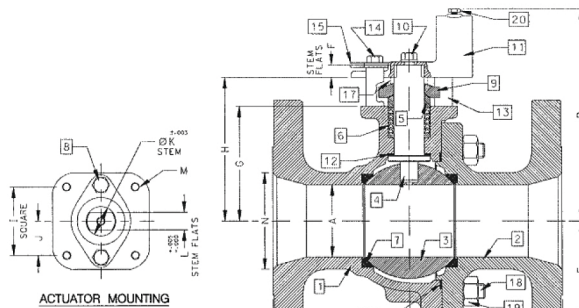

Valve Size	Valve Part No.	RMI Part No. Repair Kit
2"	88A-908-01	87A-028-01
3"	88A-900-01	87A-020-01
4"	88A-90A-01	87A-02A-01

REGO SHUTOFF VALVE REPAIR KITS

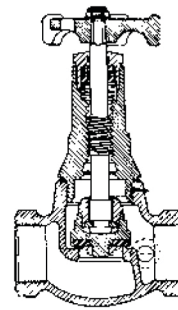

RMI Part No.	
Valve	Kit
A7505AP, A7506AP, A8016A, A7016A	A7505-50
A7507AP, A7508AP	A7507-50
A7509AP, A7510AP	A7509A-50
A7509BP, A7510BP	A7509-50
A7511AP, A7511FP, A7512AP, A7512FP	A7511-50
A7513AP, A7513FP, A7514AP, A7514FP, A7515AP, A7516AP	A7513-50
A7517AP, A7517FP, A7518AP, A7518FP	A7515-50
A7704, A7705, A7704, A7706	A7705-50

REPAIR PARTS FOR SQUIBB-TAYLOR GLOBE & ANGLE VALVES

RMI Part No.		
Valve No.	Repair Kit No.	Size
AL308, AL309	308-22	3/4"
AL-310, AL311, A1592, A1596R	310-22	1"
AL312, AL313	312-22	1 1/4"
AL314, AL315	314-22	1 1/2"
AL316, AL317	316-22	2"
AL320, AL321	320-22	3"
AL410, AL411	410-22	1/2"
AL412, AL413	410-22	3/4"

Kits Include:

- Packing
- Male Adaptor
- Seat Disc
- Body Gasket
- Gasket
- Packing Spring
- O-Ring

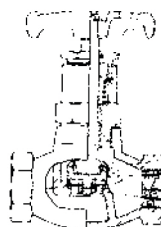

G200 AND G201 SERIES RECOMMENDED SPARE PARTS

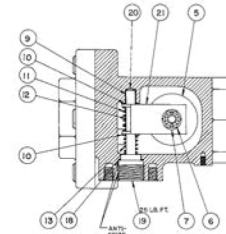
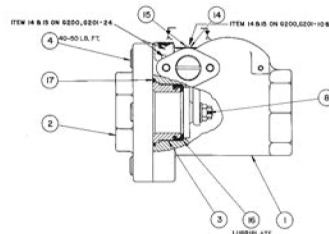

Description	RMI Part No.					
	1 1/4"		2"		3"	
	G200	G201	G200	G201	G200	G201
Seat Ring	T12857T0012		T12857X0012		T12887T0012	
Disk	T12858T0012		T12547X0012		T12891T0012	
O-Ring	10A3800X032		1H8762X0022		T12759T0012	
Gasket	T12857T0012		T12857T0012		T12782T0012	
X-Ring		T12786T0012		T12786T0012		T12786T0012