

Regulators

COMPACT HIGH PRESSURE FIRST STAGE REGULATOR

Replaces LV3303TR. Ideal for use as a first stage regulator on any domestic size ASME or DOT container in propane gas installations requiring up to 1,500,000 BTUs/hour. The use of a positive, direct-acting lever style improves performance in situations where ambient temperature is at freezing and fuel has high moisture content. Case quantity: 20 regulators.

Part no.	Inlet Connection	Outlet Connection	Orifice Size	Factory Delivery Pressure	Bonnet Vent Position	Vapor Capacity BTU/hr. Propane*
LV3403TR	1/4" F. NPT	1/2" F. NPT	1/4"	10 PSIG	Over Outlet	1,500,000
LV3403TRV9					9 O'clock	
LV3403TR9	F. POL		7/32"		Over Outlet	
LV3403TR9V9					9 O'clock	

* Maximum flow based on inlet pressure 20 PSIG higher than the regulator setting and delivery pressure 20% lower than the regulator setting.



LV3403TR9V9

COMPACT SECOND STAGE REGULATOR

The LV3403B4 is designed to reduce first stage pressure of 5-20 PSIG down to burner pressure normally 11" w.c. Designed as a second stage regulator for smaller applications with flow requirements up to 450,000 BTU/hr, they are ideal for homes, mobile homes and cottages. Large vent helps prevent vent blockage. Case quantity: 10 regulators.

Part Number	Inlet Connection	Outlet Connection	Orifice Size	Factory Delivery Pressure	Adjustment Range	Bonnet Vent Position	Vapor Capacity BTU/hr. *
LV3403B4	1/2" F.NPT	1/2" F.NPT	1/4"	11" w.c. at 10 PSIG Inlet	9" to 13" w.c.	Inlet	450,000
LV3403B4V3						3 o'clock	
LV3403B4V0						Outlet	
LV3403B4V9						9 o'clock	

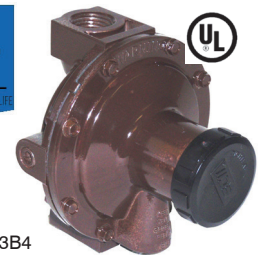

LV3403B4

COMPACT BACK-MOUNT REGULATOR

The LV3403BR Back Mount Regulator is designed to reduce first stage pressure of 5-10 PSIG down to burner pressure normally 11" w.c. Designed as a second stage regulator for smaller applications with flow requirements up to 450,000 BTU/hr. and ideal for homes, mobile homes, and cottages. Case quantity: 10 regulators.

Part no.	Inlet Connection	Outlet Connection	Orifice Size	Factory Delivery Pressure	Bonnet Vent Position	Vapor Capacity BTU/hr. Propane*
LV3403B44R	1/2" F. NPT	1/2" F. NPT	7/32"	11" wc @ 10 PSIG Inlet	Over Outlet	450,000
LV3403B46R		3/4" F. NPT				
LV3403B66R	3/4" F. NPT					

*Maximum flow based on 10 PSIG inlet and 9" w.c. delivery pressure.



LV3403B66R

HIGH PRESSURE FIRST STAGE REGULATORS

Provides accurate first stage regulation in two-stage bulk tank systems. Handles vaporization of tanks up to 1200 gallons. Reduces tank pressure to an intermediate pressure of 5 to 10 PSIG. Also used to supply high pressure burners for applications like industrial furnaces or boilers. Also incorporated in multiple cylinder installations. Integral Relief Valve Included. Case quantity: 10 regulators.

Part no.	Inlet Connection	Outlet Connection	Orifice Size	Factory Delivery Pressure (PSIG)	Adjustment Range* (PSIG)	Integral Relief Included	Vapor Capacity BTU/hr. Propane**	
LV4403SR4	1/2" F. NPT	1/2" F. NPT	1/4"	5	1-5	Yes	2,500,000	
LV4403TR4				10	5-10			
LV4403SR9	F. POL			5	1-5			
LV4403TR9					10			5-10
LV4403SR96				3/4" F. NPT	5			1-5
LV4403TR96					10			5-10

* When used for final stage pressure control, must either incorporate integral relief valve or separate relief valve should be specified in accordance with NFPA Pamphlet 58. ** Maximum flow based on inlet pressure 20 PSIG higher than the regulator setting and delivery pressure 20% lower than the setting.



LV4403TR96



Non-stock/special order items are not cancellable or returnable

Shop online at www.raymurray.com or call **800-628-5044**

Regulators



LOW PRESSURE SECOND STAGE REGULATOR - 935,000 BTU/HR

Designed to reduce first stage pressure of 5 to 20 PSIG down to burner pressure, normally 11" w.c. Ideal for medium commercial installations, multiple cylinder installations and normal domestic loads. **Backmount Design** - Mounts directly to house line piping. Eliminates need for union joints, elbows, and mounting brackets. Quick and easy to install. Case quantity: 10 regulators.

Part no.	Inlet Connection	Outlet Connection	Orifice Size	Factory Delivery Pressure	Adjustment Range	Bonnet Vent Position	Vapor Capacity BTU/hr. Propane**
LV4403B4	1/2" F. NPT	1/2" F. NPT	#28 Drill	11" w.c. at 10 PSIG Inlet	9" to 13" w.c.	Over Inlet	935,000
LV4403B46		3/4" F. NPT					
LV4403B46R*							
LV4403B66	3/4" F. NPT	3/4" F. NPT	#28 Drill	11" w.c. at 10 PSIG Inlet	9" to 13" w.c.	Over Inlet	935,000
LV4403B66R*							

* Backmount design. ** Maximum flow based on 10 PSIG inlet and 9" w.c. delivery pressure.



90° LOW PRESSURE SECOND STAGE REGULATOR - 1,000,000 BTU/HR

Designed to reduce first stage pressure down to appliance pressure, normally 11" w.c. Ideal for medium commercial installations, vapor meter installations and normal domestic loads. Its right angle design mounts to a vapor meter, or directly to the house piping.

Compact design makes for ease of installation in new and retrofit install situations. The LV4403B66RA will retrofit into existing installations that are currently using a 90°, right angle regulator.

Part no.	Inlet Connection	Outlet Connection	Orifice Size	Factory Delivery Pressure	Adjustment Range	Bonnet Vent Position	Vapor Capacity BTU/hr. Propane*
LV4403B66RA	3/4" F. NPT	3/4" F. NPT	3/16"	11" w.c. at 10 PSIG inlet	9" to 13" w.c.	Over Inlet	1,000,000
LV4403B66RAB**							

* Maximum flow is based on 10 PSIG inlet and 9" water column delivery pressure.
** Mounting bracket included



LOW PRESSURE SECOND STAGE REGULATOR - 1,600,000 - 2,300,000 BTU/HR

Designed to reduce first stage pressure of 5 to 20 PSIG down to burner pressure, normally 11" w.c. Ideal for larger commercial and industrial applications, multiple cylinder installations and large domestic systems.

Part no.	Inlet Connection	Outlet Connection	Orifice Size	Factory Delivery Pressure	Adjustment Range	Bonnet Vent Position	Vapor Capacity BTU/hr. Propane*
LV5503B4	1/2" F. NPT	3/4" F. NPT	1/4"	11" w.c. at 10 PSIG Inlet	9" to 13" w.c.	Over Inlet	1,600,000
LV5503B6	3/4" F. NPT						
LV5503B8		1" F. NPT	9/32"				2,300,000



Dielectric Second Stage Regulators



LV4403BD SERIES

Designed to reduce first stage pressure, normally 10 PSIG down to burner pressure, normally 11" w.c. and ideal for medium commercial installations, multiple cylinders installations and normal domestic loads. RegO Dielectric second stage regulators are engineered to isolate potential electrical current from metallic piping before entering a building. The use of a separate dielectric union is not necessary because the regulator contains a dielectric union as part of the inlet assembly. Available in both SAE Flare and F.NPT inlet connection. All second stage features same as LV4403B Series.



Part no.	Inlet Connection	Outlet Connection	Inlet Material	Orifice Size	Adjustment Range	Bonnet Vent Position	Vapor Capacity BTU/hr. Propane
LV4403B4D	1/2" F.NPT	1/2" F.NPT	Brass & Plated Steel	#28 Drill	9" to 13" w.c.	Over Inlet	935,000
LV4403B46D		3/4" F.NPT					
LV4403B66D	1/2" F.NPT						
LV4403B46RD							
LV4403B66RD	3/4" F.NPT						
LV4403B66RAD				1,000,000			
LV4403B66RABD							

Other sizes available. Please call Teeco for information.



LV4403Y3D SERIES

Dielectric second stage 2 PSI regulators for isolating potential electrical current from metallic piping. With 15 PSIG inlet pressure, regulator is designed to not pass more than 5 PSIG with the seat disc removed. Dielectric union is part of the inlet assembly. Straight line valve closure reduces wear on the seat disc. Replaceable valve orifice and valve seat disc. Built in pressure tap has plugged 1/8" F.NPT outlet. Plug can be removed with a 3/16" hex wrench. Large vent has 3/4" F.NPT for vent piping.



Part no.	Inlet Connection	Outlet Connection	Orifice Size	Adjustment Range	Bonnet Vent Position	Vapor Capacity BTU/hr. Propane
LV4403Y4D	1/2" F.NPT	1/2" F.NPT	1/4"	1 PSIG @ 10 PSIG Inlet	Over Inlet	1,000,000
LV4403Y46D		3/4" F.NPT				
LV4403Y66D	1/2" F.NPT					
LV4403Y46RD						
LV4403Y66RD						

Other sizes available. Please call Teeco for information.

** Maximum flow based on 10 PSIG inlet and 9" w.c. delivery pressure.

LV4403Y3D



LV5503YD SERIES

Designed to reduce first stage pressure of 10 PSIG down to 2 PSIG. A line pressure regulator is required downstream to reduce the 2 PSIG to a nominal 11" w.c. RegO Dielectric second stage regulators for 2 PSI systems are engineered to isolate potential electrical current from metallic piping before entering a building. The use of a separate dielectric union is not necessary because the regulator contains a dielectric union as part of the inlet assembly. Available in both SAE Flare and F.NPT inlet connection.



Part no.	Inlet Connection	Outlet Connection	Orifice Size	Factory Delivery Pressure	Bonnet Vent Position	Vapor Capacity BTU/hr. Propane
LV5503Y16D	1/2" M Flare	3/4" F.NPT	1/4"	2 PSIG @ 10 PSIG Inlet	Over Inlet	2,200,000
LV5503Y18D		1" F.NPT				
LV5503Y56D	5/8" M Flare	3/4" F.NPT	9/32"			
LV5503Y58D		1" F.NPT				
LV5503Y4D	1/2" F.NPT	3/4" F.NPT	1/4"			
LV5503Y6D	3/4" F.NPT	3/4" F.NPT				
LV5503Y8D		1" F.NPT				

Maximum flow based on 10 PSIG inlet and 1.5 PSIG delivery pressure.



Non-stock/special order items are not cancellable or returnable

Shop online at www.raymurray.com or call **800-628-5044**

Regulators



SECOND STAGE REGULATOR FOR 2 PSIG SYSTEMS

Designed to reduce first stage pressure of 10 PSIG down to 2 PSIG. Systems that utilize this regulator use smaller than normal piping inside of the building. A special final stage regulator, not the appliance regulator, is required to reduce this intermediate 2 PSIG pressure down to 11" w.c.

Part no.	Inlet Connection	Outlet Connection	Factory Orifice Size	Bonnet Delivery Pressure	Vent Position	Vapor Capacity BTU/hr. Propane*
LV4403Y4	1/2" F. NPT	1/2" F. NPT	1/4"	2 PSIG @ 10 PSIG Inlet	Over Inlet	1,000,000
LV4403Y46R		3/4" F. NPT				1,000,000
LV5503Y6	3/4" F. NPT	3/4" F. NPT	9/32"	2 PSIG @ 10 PSIG Inlet	Over Inlet	2,200,000
LV5503Y8		1" F. NPT				2,200,000

*Maximum flow based on 10 PSIG inlet and 2 PSIG delivery pressure.



LV4403Y Series



LOW PRESSURE SECOND STAGE TOBACCO BARN REGULATOR

Especially developed for drying barns in the tobacco industry. The LV5503G4 regulator will supply a steady and constant flow of fuel to as many as 12 to 20 burners throughout the barn.

Part no.	Inlet Connection	Outlet Connection	Orifice Size	Factory Delivery Pressure	Adjustment Range	Bonnet Vent Position	Vapor Capacity BTU/hr. Propane*
LV5503G4	1/2" F. NPT	3/4" F. NPT	1/4"	15" w.c. at 15 PSIG Inlet	8" to 18" w.c.	Above Inlet	1,750,000



LV5503G4

COMPACT TWIN STAGE REGULATOR - 525,000 BTU/HR

This compact two-stage regulator is designed to reduce container pressure down to 11" w.c. delivery pressure. It is ideal for "on-site" cylinder applications, mobile homes and average domestic service including small ASME and 100 to 420 pound DOT cylinders.

Part no.	Inlet Connection	Outlet Connection	Orifice Size	Factory Delivery Pressure	Adjustment Range	Bonnet Vent Position 1st Stage	Bonnet Vent Position 2nd Stage	Vapor Capacity BTU/hr. Propane*
LV404B4	1/4" F. NPT	1/2" F. NPT	3/16"	11" w.c. at 100 PSIG Inlet	9" to 13" w.c.	Down	Over Outlet	525,000
LV404B4V9						9 O'clock	9 O'clock	
LV404B46		Down				Over Outlet		
LV404B46V9	3/4" F. NPT	1/2" F. NPT				9 O'clock	9 O'clock	
LV404B9						Down	Over Outlet	
LV404B9V9	F. POL	1/2" F. NPT				9 O'clock	9 O'clock	
LV404B96			Down	Over Outlet				
LV404B96V9		3/4" F. NPT	9 O'clock	9 O'clock				

* Maximum flow based on 25 PSIG inlet pressure and 9" w.c. delivery pressure.



LV404B4



LV404B4V9



LV404B9

2 PSIG DELIVERY PRESSURE TWIN STAGE REGULATOR

Designed to reduce container pressure down to 2 PSIG. A line pressure regulator is required downstream to reduce the 2 PSIG to a nominal 11" W.C.

Part no.	Inlet Connection	Outlet Connection	Orifice Size	Factory Delivery Pressure	Adjustment Range (PSIG)	Bonnet Vent Position 1st Stage	2 PSIG Bonnet Vent Position	Capacity BTU/hr.
LV404Y9	F.POL (CGA 510)	1/2" F. NPT	3/16"	2 PSIG	1.8 to 2.5	Down	Outlet	800,000
LV404Y39			7/32"					650,000



Regulators

COMPACT TWIN STAGE REGULATOR - 450,000 BTU/HR

Designed to reduce container pressure down to 11" w.c. delivery pressure. Ideal for "on site" container applications such as homes, mobile homes and cottages for average domestic service, including small ASME tanks and 100-420 lb DOT cylinders.



Part Number	Inlet Connection	Outlet Connection	Orifice Size	Factory Delivery Pressure	Adjustment Range 2nd Stage	Bonnet Vent Position 1st Stage**	Bonnet Vent Position 2nd Stage**	Vapor Capacity BTU/hr*
LV404B34	1/4" F.NPT	1/2" F.NPT	7/32"	11" w.c. @ 100 PSIG Inlet	9" to 13" w.c.	Rear	Outlet	450,000
LV404B39	F. POL					Left	9:00	
LV404B34V9	1/4" F.NPT							
LV404B39V9	F. POL							

TWIN STAGE AUTOMATIC CHANGEOVER REGULATORS

These combination automatic changeover, two stage regulators are especially suitable for homes, mobile homes, cottages, construction and other portable two cylinder installations. Empty containers may be replaced without interrupting gas service.



Part no.	Inlet Connection	Outlet Connection	Factory Delivery Pressure	Adjustment Range 2nd Stage	Bonnet Vent Position 2nd Stage	Service and Reserve Indicator	Bracket Included	Vapor Capacity BTU/hr. Propane*	Pigtails Included
7525B34	1/4" Inverted Flare	1/2" F. NPT	11" w.c.	9" to 13" w.c.	Over Outlet	Integral	3403.31	400,000	912FA20 & 912FS20
7525B4							2503-22	500,000	

* Set at 100 PSIG inlet pressure. ** Maximum flow based on 25 PSIG inlet pressure and 9" water column delivery pressure.

TWO STAGE REGULATOR OUTFITS

These outfits contain the equipment required to provide two-stage regulation.



Kit Number	1st Stage Regulator Included		2nd Stage Regulator Included		Bracket Included	Pigtail Included	Capacity BTU/hr. Propane
	Part no.	Inlet x Outlet Female	Part no.	Inlet x Outlet F. NPT			
5807	LV4403TR9	POL x 1/2" NPT	LV4403B4	1/2" x 1/2"	2503-22	913PS12	935,000
5808			LV4403B46R	1/2" x 3/4"			
5820	LV4403TR96	POL x 3/4" NPT	LV4403B66R	3/4" x 3/4"	Not Required		



LV4403TR9



LV4403B4



2503-22



913PS12



Non-stock/special order items are not cancellable or returnable

Shop online at www.raymurray.com or call **800-628-5044**

Regulators



TWIN STAGE REGULATOR OUTFIT

This outfit contains the equipment required to provide twin-stage regulation.

Kit Number	Twin Stage Regulator Included	Inlet F. NPT	Outlet F. NPT	Pigtails Included	Capacity BTU/hr. Propane
5828	LV404B4	1/4"	1/2"	912JS12	525,000
5832	LV404B34V9				450,000



912JS12



LV404B4

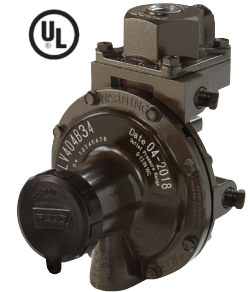

LV404B34 Series

AUTOMATIC CHANGEOVER REGULATOR OUTFITS

These outfits contain the equipment required to provide automatic changeover regulation.

Kit Number	Automatic Changeover Regulator Included	Inlet	Outlet	Pigtails Included (2)	Bracket Included	Capacity BTU/hr. Propane
5726B34	7525B34	1/4" Inverted Flare	1/2" F. NPT	912FA20	3403-31	400,000
5727B34	7525B34			912FS20	2503-22	450,000
5754B4	7525B4			912FA20		
5755B4	7525B4			912FS20		



3403-31



912FA20



2503-22



7525B34



7525B4

COMPACT REGULATORS

These compact regulators are designed for smaller outdoor grills and fish cookers. They are intended for use on small portable appliances that use 100,000 BTU's/hr. or less. They may not be used on fixed pipe systems per NFPA 58.



302

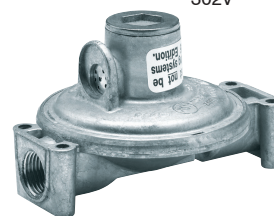

302V



302V9LS



Part no.	Type	Inlet Connection	Outlet Connection	Orifice Size	Factory Delivery Pressure	Adjustment Range	Bonnet Vent Position	Vapor Capacity BTU/hr. Propane*
302	Single Stage	1/4" F. NPT	3/8" F. NPT	No. 50 Drill	11" w.c. at 100 PSIG Inlet	9"-13" w.c.	Small Vent Above Outlet	125,000
302LS		Soft POL w/60 DMS Orifice						
302V		1/4" F. NPT					Drip Lip Above Outlet	
302V9		1/4" F. NPT					Drip Lip at 9 O'clock	
302V9LS		Soft POL w/out Orifice						

* Maximum flow based on 25 PSIG inlet and factory delivery pressure.



Non-stock/special order items are not cancellable or returnable

Shop online at www.raymurray.com or call 800-628-5044

Regulators

HIGH PRESSURE INDUSTRIAL / COMMERCIAL POUNDS TO POUNDS REGULATORS
1,750,000 to 4,500,000 BTU/hr.

Designed to reduce propane gas container pressure down to between 3 and 100 PSIG. Ideal for liquid or vapor service, they can be used in a variety of applications including salamander heaters, weed burning torches, fish cookers, tar pot heaters, and other industrial type services.

Part no.	Adjustment Method	Inlet Connection	Outlet Connection	Recommended Delivery Pressure Range	Capacity Determined at Set Pressure of PSIG*	Capacity BTU/hr. Propane**
597FA	Tee Handle	1/4" NPT	1/4" NPT	1-15	10	1,750,000
597FB				10-30	20	3,000,000
597FC				20-45	30	3,500,000
597FD				40-100	60	4,500,000
597FAY		970 Hard Nose POL		1-15	10	1,750,000
597FBY				10-30	20	3,000,000
597FCY				20-45	30	3,500,000



597 Series

* Set pressure established at 100 PSIG inlet and a flow of 250,000 BTU/hr.

** Capacity determined at actual delivery pressure 20% less than set pressure with inlet pressure 20 PSIG higher than the set pressure.

7,000,000 to 14,000,000 BTU/hr (LPG) and 2100 CFH to 8,900 CFH (NH3)

Designed to reduce LP-Gas and anhydrous ammonia container pressures to between 3 and 125 PSIG. Precision-built with a multi-million BTU capacity, the 1580V series is perfect for such big, tough jobs as crop dryers, asphalt batch mixing plants, road building "tar wagons", heat treating and other large industrial and commercial loads. It's also ideal as a first stage regulator in large multiple operations. The AA1580V series is ideal for use in anhydrous ammonia applications such as blue print machines and heat treating. See page H2 for gauges.

Part no.	Service	Adjustment Method	Inlet & Outlet Connections	Recommended Delivery Pressure Range (PSIG)	Capacity Determined at Set Pressure of PSIG*	Capacity**
1584VN	LP-Gas	Tee Handle	1/2" F. NPT	3-30	20	7,000,000 BTU/hr. LPG
1584VL				25-50	30	7,500,000 BTU/hr. LPG
1584VH				45-125	60	8,000,000 BTU/hr. LPG
AA1584VW	NH3			3-25	20	4,500 CFH NH3
AA1584VL				20-50	30	4,800 CFH NH3
AA1584VH				45-125	60	5,100 CFH NH3
1586VN	LP-Gas		3/4" F. NPT	3-30	20	11,000,000 BTU/hr. LPG
1586VL				25-50	30	12,000,000 BTU/hr. LPG
1586VH				45-125	60	14,000,000 BTU/hr. LPG
AA1586VW	NH3			3-25	20	7,000 CFH NH3
AA1586VL				20-50	30	7,700 CFH NH3
AA1586VH				45-125	60	8,900 CFH NH3
1588VN	LP-Gas	1" F. NPT	3-30	20	11,000,000 BTU/hr. LPG	
1588VL			25-50	30	12,000,000 BTU/hr. LPG	
1588VH			45-125	60	14,000,000 BTU/hr. LPG	



* Set pressure is established with 100 PSIG inlet pressure and a flow of 500,000 BTU/hr. propane for 1580V Series, 90 CFH/hr. NH3 for AA1582M Series and 180 CFH/hr. NH3 for AA1584V and AA1586V Series.

** Capacities determined at actual delivery pressure 20% less than set pressure with inlet pressure 20 PSIG higher than set pressure. NOTE: Care must be taken to prevent re-liquefaction of propane at normal temperatures by heat tracing or other effective means. Use of a relief valve upstream or downstream of these regulators is recommended in accordance with NFPA 58.



Non-stock/special order items are not cancellable or returnable

 Shop online at www.raymurray.com or call **800-628-5044**

Regulators



HIGH PRESSURE / HIGH TEMP INDUSTRIAL / COMMERCIAL POUNDS TO POUNDS REGULATORS

Designed to reduce LP-Gas container pressures to between 3 and 50 PSIG. Ideal for crop drying, heat treating, asphalt batch mixing and other large industrial and commercial load application utilizing high temperature LP-Gas or high temperature atmosphere under conditions up to 300 F. Also ideal as a first stage regulator in large multiple operations. See page H3 for gauges.



Part no.	Service	Adjustment Method	Inlet & Outlet Connections	Recommended Delivery Pressure Range (PSIG)	Capacity Determined at Set Pressure of PSIG*	Capacity**		
X1584VN	LP-Gas	Tee Handle	1/2" F. NPT	3-30	20	7,000,000		
X1584VL				25-50	30	7,500,000		
X1584VH				45-125	60	8,000,000		
X1586VN			LP-Gas	Tee Handle	3/4" F. NPT	3-30	20	11,000,000
X1586VL						25-50	30	12,000,000
X1586VH						45-125	60	14,000,000
X1588VN					1" F. NPT	3-30	20	11,000,000
X1588VL						25-50	30	12,000,000
X1588VH						45-125	60	14,000,000

* Set pressure is established with 100 PSIG inlet pressure and a flow of 500,000 BTU/hr. propane.

** Capacities determined at 100 PSIG inlet, set pressure noted on chart at 20% drop.

NOTE: Care must be taken to prevent re-liquefaction of propane at normal temperatures by heat tracing or other effective means. Use of a relief valve upstream or downstream of these regulators is recommended in accordance with NFPA 58.

ACCESSORIES FOR HIGH PRESSURE INDUSTRIAL / COMMERCIAL POUNDS TO POUNDS REGULATORS

Designed for use as a relief valve on first stage regulators that comply with NFPA 58 2.5.7.5 exception: "first stage regulators with a rated capacity of more than 500,000 BTU/hr. shall be permitted to have a separate relief valve. Pipeaway adapter also available. Part # B-9412-2B

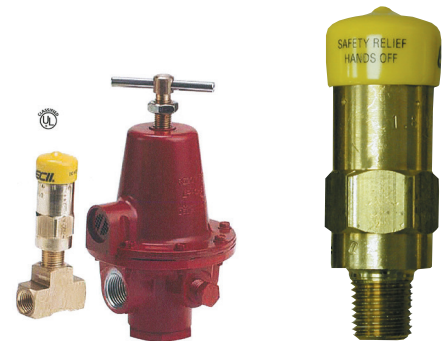

3139 Series Relief Valve shown with 1580 Series Regulator (sold separately)

3139

Part no.	Set Pressure	Regulator Settings	Connection Size	Height	Width	Flow Capacity at 120% Set Pressure (SCFH Propane)
3139-18	18 PSIG	10 PSIG	1/4" M. NPT	2 27/32"	1 1/16"	1357*
3139-26	26 PSIG	26 PSIG				1725**
3139-38	38 PSIG	38 PSIG				2304***

*Flow recorded at 21.6 PSI inlet pressure for this valve.
 **Flow recorded at 31.2 PSI inlet pressure for this valve.
 ***Flow recorded at 45.6 PSI inlet pressure for this valve.



Non-stock/special order items are not cancellable or returnable

Shop online at www.raymurray.com or call 800-628-5044

Regulators

ACCESSORIES
Copper Pigtails

Pigtails are available in a variety of connections, sizes and styles. Care should always be taken in selecting the proper pigtail for a particular application. Note: RegO recommends a new pigtail be installed with every new and replaced regulator.

STRAIGHT COPPER PIGTAILS ORDERING INFORMATION

Connections	Approximate Length	Part no.		
		Pigtails- 1/4" Tube		Hogtails - 3/8" Tube
		7/8" Hex Short Nipple	1 1/8" Hex Long Nipple	7/8" Hex Short Nipple
M. POL x M. POL	5"	—	—	913PS05
	12"	912PS12	—	913PS12
	20"	912PS20	912PA20	913PS20
	36"	912PS36	912PA36	913PS36
	48"	912PS48	912PA48	913PS48
1/4" Inverted Flare x M. POL	12"	912FS12	—	—
	20"	912FS20	912FA20	—
	30"	912FS30	—	—
	36"	912FS36	—	—
1/4" M. NPT x M. POL	5"	—	—	913JS05
	12"	912JS12	—	913JS12
	20"	912JS20	—	913JS20
	36"	912JS36	—	—
1/2" M. NPT x M. POL	12"	—	—	913LS12
1/2" M. NPT x 3/8" M. NPT	12"	—	—	913KL12



913PS12

BENT COPPER PIGTAILS ORDERING INFORMATION

Connections	Approximate Length	Type / Degree of Bend	Part no. 3/8" Tube 7/8" Hex Short Nipple
1/4" M. NPT x M. POL	5"	90°	913JS05A
M.POL x M. POL			913PS05A
M.POL x M. POL	12"	270° Right Hand	913PS12G
		270° Left Hand	913PS12H
		360°	913PS12S

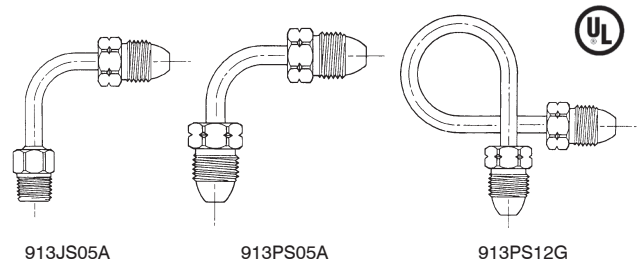
PIGTAIL / GAUGE TAIL LEAK CHECK SYSTEM

Some customers often experience service interruptions (out of gas occurrences). For propane marketers to deal with these types of customers more effectively, RegO has developed the 612 series Pigtail/gauge tail leak check system. These "gauge-tails" make performing the required NFPA 54 leak test a quick, easy and dependable procedure. The UL Listed pigtails provide a built in pressure test block and bleeder valve for leak testing installations per the requirements in NFPA 54.

Part no.	Length	Description
612JS12	12"	7/8" hex male-POL short nipple x 1/4" M. NPT
612PS12		7/8" hex male-POL short nipple x 7/8" hex M. POL short nipple
612JS20	20"	7/8" hex male-POL short nipple x 1/4" M. NPT
612PS20		7/8" hex male-POL short nipple x 7/8" hex M. POL short nipple

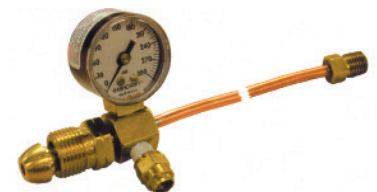

Regulators



DIELECTRIC PIGTAILS

D912 Series Electrically Isolated Pigtails for Underground Containers

These Pigtails are designed specifically for use on Underground LP-Gas Containers where dielectric isolation is necessary to protect the container.

Part no. 1/4" Tube 7/8" Hex Short Nipple	Connections	Approximate Length
D912P12	M.POL x M.POL	12"
D912P20		20"
D912P30		30"
D912J12	1/4" M.NPT x M.POL	12"
D912J20		20"
D912J30		30"

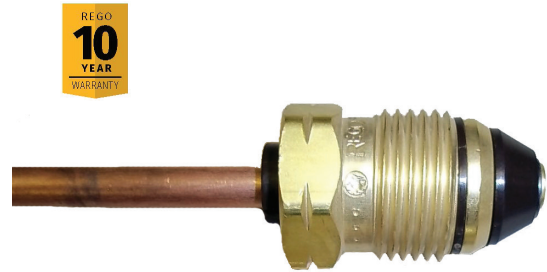

INLET FITTINGS

These inlet fittings are available for assembly into either first stage of single stage regulators. All have 1/4" M. NPT connections and are machined from brass.

Part no.	Description
970	Hard nose POL with wrench nut
970AX	Hard nose POL with wrench nut and excess flow.
970AXS	Soft nose POL with wrench nut and excess flow.
970AW	Soft nose POL with handwheel.
970HT	Soft nose POL with handwheel and 60 DMS orifice.
970S	Soft nose POL with wrench nut and 60 DMS orifice.
3199W	Heavy duty hard nose POL with wrench nut and excess flow.



ADJUSTABLE FLEXIBLE VENT KIT

The LV960 Series Adjustable vent kit is designed to assist in meeting the point of discharge requirements for regulators in NFPA 58; it does this by diverting the LP-Gas vapor away from sources of ignition, openings into direct vent appliances or mechanical air intakes.

Part no.	Flex Tubing Length	Reusable End Connectors	90° Elbow	Mounting Bracket & Screws
LV960-48	48" (4 feet)	2	1	3
LV960-72	72" (6 feet)			4
LV960-120	120" (10 feet)			5



Regulators

BRACKETS

RegO brackets are especially designed for use in installing RegO regulators in applications requiring the use of a bracket.

Part no.	Material	For use with Regulator Model:
3403-31	Cadmium Plated Steel	LV3403, LV404B34, LV404B39 & LV404Y39
2503-22		LV404 Series, 2503 Series, LV4403 Series
2503-19	Aluminum	



2503-19



2503-22



3403-31

TEE CHECK MANIFOLDS

For use in systems that require uninterrupted gas service during cylinder exchange. Especially for summer cottages, mobile homes and single appliance loads. Floating disc check minimizes discharge of gas to the atmosphere when empty cylinder is being replaced.

Part no.	Inlet Connections	Outlet Connections
1350R	F. POL	M. POL
1450R	1/4" Inverted Flare	1/4" M. NPT



1350R

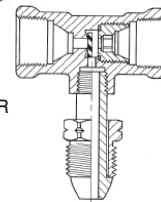

1450R



MULTIPLE CYLINDER MANIFOLDS

Use with suitable pigtailed to connect multiple cylinders together. Ideal for loads that require more than one cylinder to be in service at a time. Provides a three-way tee function without an internal disc check.

Part no.	Inlet Connection	Outlet Connections
1350E	F. POL	M. POL
1450E	1/4" Inverted Flare	1/4" M. NPT

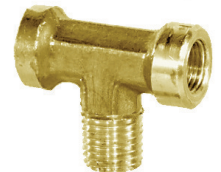
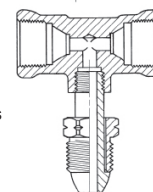

1350 Series



1450E



Regulators



LOW PRESSURE TEST SET

This kit provides the equipment necessary for checking regulator delivery pressure (low pressure) at the appliances. The basic set contains a 2424A-2 low pressure gauge with multi-color dial and a 3 foot - 3/16" O.D. flexible synthetic rubber tube. Adapters are also available.



2434A

Part no.	Contents
2434AK	Test Kit and all Adapters
2434A	Test Kit Only
2434A-11	Hose Tip



1328 Adapter

Adapters	Description
1328	3/8" M. Flare x 3/8" F. Flare Swivel
1331	1/2" M. Flare x 1/2" F. Flare Swivel
1332	5/8" M. Flare x 5/8" F. Flare Swivel

HIGH PRESSURE GAUGE ADAPTER

Designed for testing high pressure lines. Adapter has 0 to 300 PSIG gauge. A bleeder valve allows you to bleed down to correct pressure during pressure tests.

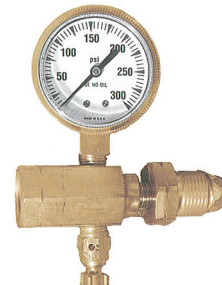

2962

Part no.	Inlet Connection	Outlet Connection	Pressure Gauge Range (PSIG)
2962	Soft Nose M. POL	F. POL	0-300

WATER MANOMETER KIT

The water manometer kit is especially suited for use with low pressure LP-Gas systems. It is ideal for pressure checks down-stream of the low pressure regulator and at the appliances.

Part no.	Description
1212 KIT	Flexible Tool Water Manometer Kit



Replacement Parts

Part no.	Description
1211-16	Slack Tube Manometer
A-126	Fluorescent Green Color Concentrate 3/4 oz.
A-201	Rubber Tubing 3/16" ID, 9 ft
A-339	Adapter, Brass for 1/8" MPT to 3/16" Rubber & 1/8" ID Plastic Tube
410134-00	Replacement Rubber Elbow



Non-stock/special order items are not cancellable or returnable

Shop online at www.raymurray.com or call 800-628-5044

Presto-Tap Leak Detection System

PRESTO-TAP LEAK DETECTION SYSTEM

The UL listed Presto-Tap Leak Detection System line of products offers an efficient way for drivers to test for leaks, obtain pressure readings and confirm the presence of gas in LP tanks. The easy-to-use system requires no special tools and only minimal training, so drivers and servicemen can easily comply with industry-mandated leak detection and documentation procedures.

Presto-Tap products meet NFPA 54 & 58 specifications. Can be adapted for use with gauges and equipment you already have. Save time and money by never breaking the system to perform system leak tests. Streamline service, risk management and loss control obligations. Available exclusively from RegO Master Distributors.

Pigtails & Hogtails

Patented Pigtail and RV products are Made in the USA by RegO.

Part no.	Description
PT912FS20	20" POL x 1/4 Inverted Flare
PT912JS12	12" POL x 1/4 Pigtail
PT912JS20	20" POL x 1/4 Pigtail
PT912PS12	12" POL x POL Pigtail
PT912PS20	20" POL x POL Pigtail
PT912PS48	48" POL x POL Pigtail
PT913JS12	12" 3/8 POL x 1/4 Hogtail
PT913PS12	12" 3/8 POL x POL Hogtail

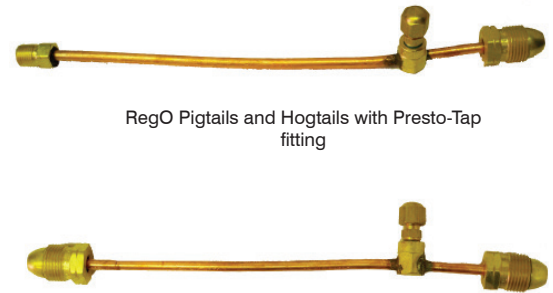

RegO Pigtails and Hogtails with Presto-Tap fitting

Ambient Temperature Gauges

Patented, liquid filled 300psi / Glycerin Filled Ambient Temperature Gauge (indicates liquid in the tank, not just vapor pressure.) Inner red dial is the temperature reading that should closely correspond to the pressure reading (outer black dial) if liquid is in the tank. The 90° Quick Adapter provides access to the Presto-Tap Valve without tools.

Part no.	Description
PT6800-90	Presto-Tap 300 psi / Ambient Temperature Gauge w/ 90° Quick Adapter & Belt Loop Holster
PT6800-B90	Presto-Tap 300 psi / Ambient Temperature Gauge w/Bleeder Valve, 90° Quick Adapter & Holster
PT6800-BH90	Presto-Tap 300 psi / Ambient Temperature Gauge w/Bleeder Valve, 90° Quick Adapter & 12" Hose
PT6800-BS	Presto-Tap 300 psi / Ambient Temperature Gauge w/Bleeder Valve, Straight Quick Adapter
PT6800-BHS	Presto-Tap 300 psi / Ambient Temperature Gauge w/Bleeder Valve, Straight Quick Adapter & 12" Hose
PT6800-BHX	Presto-Tap 300 psi / Ambient Temperature Gauge w/Bleeder Valve, Straight Quick Adapter & 36" High Pressure Flex Hose
H-FLX	36" High Pressure Flex Hose with 1/4" x 1/4" Brass Coupling
6800D-90	Presto-Tap 300 psi / Dry Ambient Temperature Gauge w/ 90° Quick Adapter & Belt Loop Holster
6800D-B90	Presto-Tap 300 psi / Dry Ambient Temperature Gauge w/Bleeder Valve, 90° Quick Adapter & Holster
6800D-BH90	Presto-Tap 300 psi / Dry Ambient Temperature Gauge w/Bleeder Valve, 90° Quick Adapter & 12" Hose
LDS2000-TG	Test Gauge - for testing of Mobile #6800 Gauge



PT6800-BH90

Low Pressure Gauges

Part no.	Description
PT30LP-BHX	Presto-Tap 30# Low Pressure Gauge w/Bleeder Valve, Straight Quick Adapter & 36" Hose
PT30LP-BH90	Presto-Tap 30# Low Pressure Gauge w/Bleeder Valve, Hose & 90° Quick Adapter
PT30LP-BHS	Presto-Tap 30# Low Pressure Gauge w/Bleeder Valve, Hose & Quick Adapter - Straight



PT30LP



PT30LP-BHX

20 oz Gauge with Bleeder Valve

Part no.	Description
PTOZ	Presto-Tap 20oz Gauge w/Bleeder Valve
PTOZ-BHX	Presto-Tap 20oz Gauge w/Bleeder Valve, Straight Quick Adapter & 36" Hose



PTOZ

Regulators



PRESTO-TAP LEAK DETECTION SYSTEM (CONT'D)

RV-L Regulator Valve- Low Pressure. (50 per bag) The RVL low pressure fitting is designed to obtain pressure readings at first and second stage regulators. Compatible with all Presto-Tap® gauge products when used at correct locations. Not legal at Tank Pressure Locations and not recommended for interior use. Not UL Listed.



RV-L

Part no.	Description
RVL	Presto-Tap Regulator Valve - Low Pressure (50/bag)

Quick Adapters

Quick Adapter - 1/4" F.NPT x Presto-Tap Pressure Valve Connector for access using industry standard testing devices.

Part no.	Description
RV-QA-90	Presto-Tap Quick Couple Adapter - 90° (for testing w/non-Presto-Tap gauges and other instruments)
RV-QA-STRAIGHT	Presto-Tap Quick Couple Adapter - Straight (for testing w/non-Presto-Tap gauges and other instruments)
RV-QAGASKET	RV/QA (Quick Adapter) Replacement Gasket



RV-QA-90

Fittings, Valves and Tools

Part no.	Description
LDS2000RV	Tank & Regulator Pressure Fitting w/54 Orifice
TPF	Tank Pressure Fitting (Tee) -F. NPT 1/4" x M. NPT 1/4" x 1/8" Pressure Tap (10/box)
LPV	Replaced by TPF - See above
GAUGE BLEEDER VALVE	Bleeder Elbow - 1/4" Male x 1/4" Female with Side Valve
LPVTOOL	LPV "Tamper Resistant" Tool



LDS2000RV



TPF



LPV

Universal Service Tech Kit

The ideal Leak Testing Kit for Service Techs.

Includes: 300# ambient temperature gauge, 30# gauge, 5# gauge and 0-35" wc gauge; Manometer adapter; 3/16" Hex Key; 36" Universal Flex Hose w/ gauge bleeder and adapters; (6) LDS2000-RV fittings and a 12" Nylon Tool Bag.

Part no.	Description
PTU-KIT	Leak Testing Kit for Service Techs. Please see above for list of items included



Replacement Gauges

Part no.	Description
300LBW	Presto-Tap 300# Glycerin Filled Replacement Gauge
PT30LP-KGA	Presto-Tap 30# Replacement Gauge
PTOZ-KGA	Presto-Tap 20oz Replacement Gauge



300LBW

Accessories & Additional Items

Part no.	Description
HOLSTER	Presto-Tap Belt-Loop Cloth Holster
14MMHX36-KIT	Flex Hose w/Bleeder Valve and (2) RV-QA Straight
MHA-S	Manometer Hose Adapter - Gauge Bleeder Valve, Hose Barb & Straight Quick Adapter



HOLSTER

LPG Cylinder & Service Valves

HEAVY DUTY CYLINDER VALVES FOR VAPOR WITHDRAWAL

This heavy duty cylinder valve is designed for vapor withdrawal of DOT cylinders up to 100 lbs. propane capacity. It is used in domestic hookups, with RV's and as a heavy duty barbecue cylinder valve.

Approximate Filling Rate Liquid Flow, GPM			
Pressure Drop Across Valves			
10 PSIG	25 PSIG	50 PSIG	100 PSIG
12.7	20.3	29.0	41.3

Part no.*	Container Connection	Service Connection	Fixed Liquid Level Vent Valve Style	Dip Tube Length With Deflector	Pressure Relief Valve Setting	For use in Cylinders with Propane Capacity up to:	Accessories
							POL Plug
9103D4.2	3/4" M. NGT	F. POL (CGA 510)	Knurled	4.2"	375 PSIG	100 lbs.	N970P
9103D10.6				10.6"			
9103D11.6				11.6"			

* "D" Prefix denotes #72 Low Emission version.

CYLINDER VALVE FOR RV AND SMALL ASME SYSTEM VAPOR WITHDRAWAL

Designed especially for vapor withdrawal service in small ASME containers with surface area up to 23.8 square feet. UL flow capacity is 645 CFM/air, per NFPA 58.

Part no.	Container Connection	Service Connection	Fixed Liquid Level Vent Valve Style	Pressure Relief Valve Setting	For use in Cylinders with Propane Capacity up to:	Flow Capacity SCFM/Air
9106CO	3/4" M. NGT	F. POL (CGA 510)	None	312 PSIG	ASME Tanks*	645

* Surface area up to 23.8 square feet.

CYLINDER VALVE FOR LIQUID WITHDRAWAL

Equipped with excess flow valves and liquid withdrawal tubes, they are designed for liquid withdrawal of DOT cylinders up to 100 lbs. propane capacity. They are most often used with heavy BTU loads found in industrial uses.

Part no.**	Container Connection	Service Connection	Fixed Liquid Level Vent Valve Style	Dip Tube Length With Deflector	Liquid Withdrawal Tube Length
9107K8A*	3/4" M. NGT	CGA 555	Knurled	11.6"	44"

* Use adapter 12982 to connect to pipe threads.

Pressure Relief Valve Setting	For use in Cylinders with Propane Capacity up to:	Approximate Filling Rate Liquid Flow, GPM				Closing Flow (LP Gas)*		
		Pressure Drop Across Valves				Vapor		Liquid
		10 PSIG	25 PSIG	50 PSIG	100 PSIG	25 PSIG Inlet	100 PSIG Inlet	
375 PSIG	100 lbs.	3.3	5.4	7.7	11.1	525 SCFH	1,000 SCFH	1.7 GPM

*Closing flows based on 3/8" O.D. withdrawal tube 44" long or less attached. IMPORTANT: 1/4" O.D. pigtailed or POL connections for 1/4" O.D. pigtailed should not be used with these valves. NOTES: To ensure proper functioning and maximum protection from excess flow valves, the cylinder valve should be fully opened and backseated when in use. These valves incorporate an excess flow valve. Refer to L-500, Section F for complete information regarding selection, operation and testing of excess flow valves.

** "D" Prefix denotes #72 Low Emission version.



9107K8A



LPG Cylinder & Service Valves



DUAL CYLINDER VALVE FOR SIMULTANEOUS LIQUID AND VAPOR WITHDRAWAL

This dual cylinder valve was designed especially for industrial uses. It increases the cylinder's flexibility by permitting DOT cylinders up to 100 lbs. propane capacity to be used interchangeably or simultaneously for either liquid or vapor withdrawal.

Part no.	Container Connection	Service Connection		Fixed Liquid Level Vent Valve Style	Liquid Withdrawal Tube Length
		Vapor	Liquid		
8556	* 3/4" M. NGT	F. POL (CGA 510)	CGA 555	None	44"

* Use adapter 12982 to connect to pipe threads.

Pressure Relief Valve Setting	For use in Cylinders with Propane Capacity up to:	Approximate Filling Rate Liquid Flow, GPM				Liquid Closing Flow (LP-Gas)
		Pressure Drop Across Valves				
		10 PSIG	25 PSIG	50 PSIG	100 PSIG	
375 PSIG	100 lbs.	6.6	10.0	14.5	21.0	2.3 GPM

* To ensure proper functioning and maximum protection from integral excess flow valves, the cylinder valve should be fully opened and backseated when in use. NOTE: These valves incorporate an excess flow valve. Refer to L-500, Section F, for complete information regarding selection, operation and testing of excess flow valves.



8556

SERVICE VALVES FOR ASME & DOT CONTAINERS / FUEL LINES

Designed especially for vapor withdrawal service on ASME and DOT containers or in fuel line applications. Since none of these valves have an integral pressure relief valve, they may only be used as an accessory valve on containers that have an independent pressure relief valve sufficient for that container's capacity.

Part no.*	Container Connection	Service Connection	Bonnet Style	Fixed Liquid Level Vent Valve	Approximate Filling Rate Liquid Flow, GPM			
					Pressure Drop Across Valves			
					10 PSIG	25 PSIG	50 PSIG	100 PSIG
901C1	3/4" M. NGT	F. POL (CGA 510)	Standard	No	5.3	8.2	10.8	14.2
9101C1				8.8	12.4	15.8	21.7	
9101D11.1				Yes	8.6	12.7	16.3	22.3
9101D11.7				8.6	12.7	16.3	22.3	
9101R1			MultiBonnet	No	7.6	11.7	15.2	20.6
9101R11.1				Yes				
9101R11.7				Yes				



901C1

9101D

9101R1

RegO 9102 Series Vapor Service Valves with Pressure Test Port

Includes 1/8" F.NPT pressure test port. With the service valve closed, the pressure test port will be isolated from the container. This will allow a high-pressure leak test to be conducted without disconnecting the pigtail from the service valve.

Part no.*	Bonnet Style	Container Connection	Service Connection	Fixed Liquid Level
9102D11.1	Standard	3/4" M.NPT	F.POL CGA 510	Yes
9102D11.7				No
9102R1	Multibonnet			No
9102R11.1				Yes
9102R11.7				Yes



RegO Ready to Go PT9102 Series

Rego 9102 Series Vapor Service Valve with Presto-Tap fitting included, providing a simple and cost efficient method of quickly and easily performing system pressure checks.

Part no.*	Description
PT9102D11.1	RegO Vapor Service Valves with Presto-Tap Fitting
PT9102D11.7	
PT9102R1	
PT9102R11.1	
PT9102R11.7	



PT9102 Series

* "D" Prefix denotes #72 Low Emission version.



Non-stock/special order items are not cancellable or returnable

Shop online at www.raymurray.com or call 800-628-5044

LPG Cylinder & Service Valves

SERVICE VALVES FOR ASME AUTOGAS CONTAINERS

Designed specifically for vapor or liquid withdrawal service on ASME Autogas containers. *Since none of these valves have an integral pressure relief valve, they may only be used as an accessory valve on containers that have an independent pressure relief valve sufficient for that container's capacity.* The integral excess flow valve found in all these service valves helps prevent excessive product loss in the event of fuel line rupture. When installed for liquid withdrawal, the 9101H6 has provisions for attachment of a liquid withdrawal tube. All other valves must be installed in containers that have provisions for a separate liquid withdrawal. *To insure proper functioning and maximum protection from integral excess flow valves, these service valves should be fully opened and backseated when in use.*

Part no.	Container Connection	Service Connection	Liquid Withdrawal Connection	Closing Flow (LP-Gas)		
				Vapor		Liquid GPM
				25 PSIG Inlet	100 PSIG Inlet	
9101C5	3/4" M. NGT	F. POL CGA 510	None	550***	1,050***	2.6***
9101H5*		3/8" SAE Flare	1/4" NPT	765**	1,300**	3.6**
9101H6*				550****	1,050****	2.6****
9101Y5H*		60° Angle 3/8" SAE Flare	None	765**	1,300**	3.6**

* Heavy-duty models. ** Based on 3/8" O.D. pigtail, 20" long or less, connected to valve outlet. For greater lengths, the pigtail must have a larger O.D. *** Same as (**). In addition, 1/4" O.D. pigtails or POL connections for 1/4" O.D. should not be used with this valve. **** Based on 3/8" O.D. pigtail; 20" long or less, connected to valve outlet. Also based on 1/4" pipe size dip tube, 42" long or less, attached to special inlet connection. For longer pigtail lengths, the diameter of the pigtail must be increased. NOTE: These valves incorporate an excess flow valve. Refer to L-500, Section F for complete information regarding selection, operation and testing excess flow valves.

SERVICE VALVES FOR DOT FORKLIFT CONTAINERS

Designed specifically for vapor or liquid withdrawal service on DOT forklift containers. Valves with 1.5 GPM closing flow are for use in small and medium size lift truck applications, while those with 2.6 GPM closing flow are for large lift trucks and gantry crane type vehicles. *Since none of these valves have an integral pressure relief valve, they may only be used as an accessory valve on containers that have an independent pressure relief valve sufficient for that cylinder's capacity.* The integral excess flow valve found in all these service valves helps prevent excessive product loss in the event of fuel line rupture.

When installed for liquid withdrawal, the 9101P6 Series has provisions for attachment of a liquid withdrawal tube. The 9101P5 Series must be installed in containers that have provisions for a separate liquid withdrawal. To insure proper functioning and maximum protection from integral excess flow valves, these service valves should be fully opened and backseated when in use.

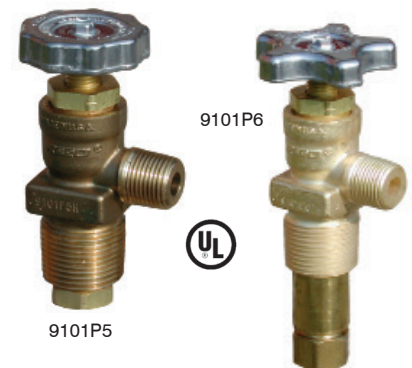

Part no.	Container Connection	Service Connection	Liquid Withdrawal Connection	Closing Flow (LP-Gas)			Approximate Filling Rate Liquid Flow, GPM				Accessories		
				Vapor		Liquid (GPM)	Pressure Drop Across Valve				ACME Check Connectors		
				25 PSIG Inlet (SCFH)	100 PSIG Inlet (SCFH)		10 PSIG	25 PSIG	50 PSIG	100 PSIG	Male	Female	Cap
9101P5	3/4" M. NGT	3/8" M. NPT	None	430	900	1.5	5	7.6	10.7	14.9	7141M	7141F	7141M-40 or 7141FP
9101P5H				550	1,050	2.6							
9101P6			1/4" NPT	430	900	1.5	4.5	7.2	10.3	14.8			
9101P6H				550	1,050	2.6							

NOTE: These valves incorporate an excess flow valve. Refer to L-500/Section F, for complete information regarding selection, operation and testing of excess flow valves.



Non-stock/special order items are not cancellable or returnable

Shop online at www.raymurray.com or call **800-628-5044**

Multivalve Assemblies



MULTIVALVE WITH LOW EMISSION DOUBLE BACK CHECK FILLER VALVE

Important: When utilizing an unloading adapter with a RegO valve, use RegO adapters only.

These Multivalves® are designed for use in single opening ASME containers equipped with a 2-1/2" riser or male pipe thread. They can be used with underground or above ground containers; a separate opening is required for liquid withdrawal.

Combines low emission double back check filler valve, vapor equalizing valve, pressure relief valve, service valve, fixed liquid level gauge, "junior" sized float gauge flange opening and a plugged pressure gauge opening. • Double back check filler valve is low emission, 2.13cc at disconnection no reduction in fill rates. • Service valve features a MultiBonnet® stem assembly that allows for repair without evacuating gas from the container. • Designed for installation of a 1/8" FNPT pressure gauge or pressure gauge connection like the Presto-Tap®.

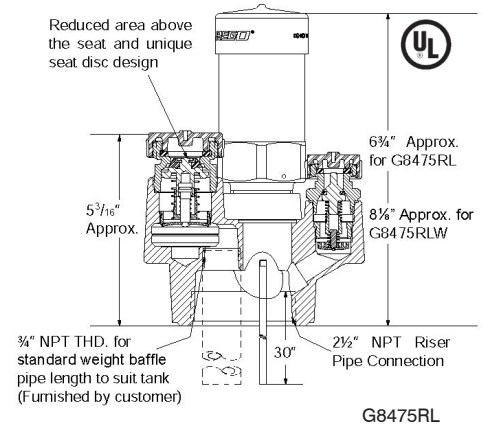

Part no.	Container Connection	Approximate Filling Rate Liquid Flow, GPM				Accessories Extended Fill Adapter
		Pressure Drop Across Valve				
		10 PSIG	25 PSIG	50 PSIG	100 PSIG	
G8475RL	2 1/2" FNPT	42	72	98	125	8475-50L
G8475RLW						

Note: G8475RL replaces G8475RV. G8475RLW replaces G8475RW.

RegO Ready to Go PG8475 Series - Includes Presto-Tap fitting.

Presto-Tap Fitting provides a cost efficient and simple method of quickly and easily performing system pressure checks.

Part no.	Description
PG8475RL	RegO ASME Multivalve with Presto-Tap Fitting
PG8475RW	



PG8475 Series



Part no.	Container Connection	Service Connection	Filling Connection	Vapor Equalizing Connection	Float Gauge Flange Opening	Fixed Liquid Level Gauge / Tube	Relief Valve Part #	Relief Valve Setting
G8475RL*	2 1/2" F. NPT	F. POL (CGA 510)	1 3/4" M. ACME	1 1/4" M. ACME	Fits "JUNIOR" Size	Yes - 30"	M3131G	250 PSIG
PG8475RL**								
G8475RLW							MV3132G	

*Pressure test port

**Presto-Tap installed in pressure test port

"D" Prefix denotes #72 Low Emission version.

ASME MULTIVALVES FOR VAPOR WITHDRAWAL

These Multivalves® provide vapor withdrawal and filling of ASME containers. A separate pressure relief valve is required in addition to this valve. The MultiBonnet® is standard on this valve. MultiBonnet® allows quick and easy repair of bonnet.

Part no.	Container Connection	Approximate Filling Rate Liquid Flow, GPM			
		Pressure Drop Across Valve			
		10 PSIG	25 PSIG	50 PSIG	100 PSIG
8593AL16.0	1 1/2" MNPT	42	72	98	125

Note: 8593AL16.0 replaces 8593AR16.0

"D" Prefix denotes #72 Low Emission version.



8593AL16.0



Non-stock/special order items are not cancellable or returnable

Shop online at www.raymurray.com or call **800-628-5044**

Multivalve Assemblies

DOT MULTIVALVE FOR LIQUID WITHDRAWAL

These Multivalves® permit liquid withdrawal from DOT cylinders with up to 100 lbs. propane capacity. They eliminate unnecessary cylinder handling when servicing high volume loads and allow on-site filling into the vapor space without interrupting gas service.



8555DL11.6

Part no.	Approximate Filling Rate Liquid Flow, GPM			
	Pressure Drop Across Valve			
	10 PSIG	25 PSIG	50 PSIG	100 PSIG
8555DL11.6 *	8	23	34	42

* Use adapter 12982 to connect to pipe threads.

"D" Prefix denotes #72 Low Emission version.

Container Connection	Service Connection	Filling Connection	Fixed Liquid Level Vent Valve Style	Dip Tube Length with Deflector	Liquid Withdrawal Tube Length	Pressure Relief Valve Setting	For use in Cylinders w/ Propane Capacity Up to:	Liquid Closing Flow (LP-Gas)**
3/4" M. NGT	CGA 555*	1 3/4" M. ACME	Knurled	11.6"	44"	375 PSIG	100 lbs.**	1.7 GPM

* Use adapter 12982 to connect to pipe threads.

** Per CGA Pamphlet S-1.1.

*** To ensure proper functioning and maximum protection from integral excess flow valves, the cylinder valve should be fully opened and backseated when in use.

DOT MULTIVALVES FOR VAPOR WITHDRAWAL

These Multivalves® permit vapor withdrawal from DOT cylinders with up to 200 lbs. propane capacity. They allow on-site cylinder filling without interrupting gas service. The MultiBonnet® option allows quick and easy repair of bonnet.



8555D Series

Part no.	Approximate Filling Rate Liquid Flow, GPM			
	Pressure Drop Across Valve			
	10 PSIG	25 PSIG	50 PSIG	100 PSIG
6555D Series	8	23	34	42
6555R Series				
8555D Series				
8555R Series				

Part no.	Bonnet Style	Application	For use in Containers with Size Up to:	Dip Tube Length with Deflector	Container Connection	Service Connection	Filling Connection	Fixed Liquid Level Vent Valve Style	Pressure Relief Valve		
									Setting	Flow Capacity*	
										UL Listing	ASME
6555R10.6	MultiBonnet	ASME Containers	25 sq. Ft. Surface Area or 60 Gal. Water Capacity	10.6"	3/4" M. NGT	F. POL (CGA 510)	1 3/4" M. ACME	Knurled	250 PSIG	793 SCFM / Air	700 SCFM / Air
6555R11.6	MultiBonnet			11.6"							
6555R12.0	MultiBonnet			12.0"							
8555D10.6	Standard	DOT Cylinders	200 lbs. Propane	10.6"					375 PSIG	N/A	N/A
8555R10.6	MultiBonnet			11.6"							
8555D11.6	Standard										
8555R11.6	MultiBonnet										

* Per CGA Pamphlet S-1.1.

"D" Prefix denotes #72 Low Emission version.



Non-stock/special order items are not cancellable or returnable

Shop online at www.raymurray.com or call **800-628-5044**

Multivalve Assemblies



DOT AND ASME MULTIVALVES FOR VAPOR WITHDRAWAL

These Multivalves® permit vapor withdrawal from ASME containers up to 50 sq. ft. surface area and DOT containers up to 420 lbs. propane capacity. They allow on-site cylinder filling without interrupting gas service. The MultiBonnet® option allows quick and easy repair of bonnet.



6532R Series

Part no.	Approximate Filling Rate Liquid Flow, GPM			
	Pressure Drop Across Valve			
	10 PSIG	25 PSIG	50 PSIG	100 PSIG
6532A12.0 / 6532R12.0	11	16	23	28
6542A12.0* / 6542R12.0*	23	32	46	57
6533A10.5 / 6533R10.5	11	16	23	28
6533A11.7 / 6533R11.7				
6543A11.1* / 6543R11.1*	23	32	46	57
6543A11.7* / 6543R11.7*				

* Also available with Presto-Tap - Add PT prefix.

Part no.	Bonnet Style	Application	Container Connection	Service Connection	Filling Connection	Fixed Liquid Level Vent Valve Style	Dip Tube Length with Deflector	Pressure Relief Valve Setting	For Use in Cylinders w/ Propane Capacity Up to:**	For Use in Containers w/ Surface Area Up to:***			
6532A12.0	Standard	ASME*	3/4" M. NGT	F. POL (CGA 510)	1 3/4" M. ACME	Knurled	12.0"	250 PSIG	—	43 Sq. Ft.			
6532R12.0	MultiBonnet									1" M. NGT	53 Sq. Ft.		
6542A12.0	Standard		DOT								3/4" M. NGT	375 PSIG	420 lbs. Propane
6542R12.0	MultiBonnet									1" M. NGT			10.5"
6533A10.5	Standard	11.7"											
6533R10.5	MultiBonnet			11.1"									
6533A11.7	Standard	11.7"											
6533R11.7	MultiBonnet												
6543A11.1	Standard												
6543R11.1	MultiBonnet												
6543A11.7	Standard												
6543R11.7	MultiBonnet												

* UL rated flow capacities are: 6532A12.0-1180 SCFM/air, 6542A12.0-1530 SCFM/air. ** Per CGA Pamphlet S-1.1. *** From NFPA, Appendix D. "D" Prefix denotes #72 Low Emission version.

ASME COMPACT MULTIVALVE FOR VAPOR WITHDRAWAL

These compact Multivalves® are especially suited for vapor withdrawal of ASME containers where compact groupings of components are necessary. Separate filler valves and pressure relief valves are required. MultiBonnet® allows quick and easy repair of bonnet. Now with 1/8" NPT test gauge port.

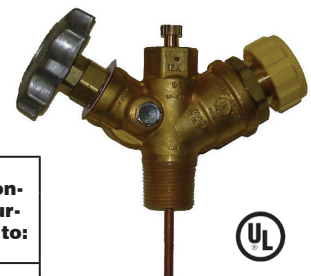

7556R12.0



Part no.	Container Connection	Service Connection	Vapor Equalizing Connection		Fixed Liquid Level Vent Valve Style	Dip Tube Length	For Use in Containers w/ Surface Area Up to:
			Connection Size	UL Listed Closing Flow			
7556R12.0	3/4" M. NGT	F. POL (CGA 510)	1 1/4" M. ACME	4,200 CFH @ 100PSIG	Knurled	12"	*

* Since these Multivalves® have no integral pressure relief valves, they can be used on any ASME container with an independent relief device sufficient for that tank's capacity. As of 2007, RegO made a change to the body of the 7556R Series. The gauge connection was moved and outlet reduced from 1/4" to 1/8" F-NPT. "D" Prefix denotes #72 Low Emission version.

RegO Ready to Go PT7556 Series - Includes Presto-Tap fitting.

Part no.	Description
PT7556R12.0	RegO ASME Multivalve for Vapor Withdrawal with Presto-Tap Fitting



PT7556 Series

Pressure Relief Valves

POP ACTION PRESSURE RELIEF VALVES -GENERAL INFORMATION

The "Pop-Action" design permits the Rego® Pressure Relief Valve to open slightly to relieve moderately excessive pressure in the container. When pressure increases beyond a predetermined point, the valve is designed to "pop" open to its full discharge capacity, reducing excess pressure quickly. This is a distinct advantage over ordinary valves which open gradually over their entire range, allowing excessive pressure to develop before the relief valve is fully open. All Rego® internal, semi-internal, and external relief valves incorporate this "Pop-Action" design. Relief valves in this catalog are only intended for use in LP-Gas or anhydrous ammonia service. Do not use any relief valve contained in this catalog with any other service commodity.

FULLY INTERNAL "POP-ACTION" PRESSURE RELIEF VALVES FOR TRANSPORTS AND DELIVERY TRUCKS

Designed specifically for use as a primary relief valve in ASME transports and delivery trucks with 2" and 3" NPT couplings.



A8434 Series



Part no.	Start to Discharge Setting (PSIG)	Container Connection	Overall Height (approx.)	Height Above Coupling (approx.)	Flow Capacity SCFM / Air		Suitable for Tanks with Surface Area Up to:*	Protective Cap Included
					UL (at 120% of Set Pressure)	ASME (at 120% of Set Pressure)		
A8434N	265	2" M. NPT	9 1/16"	1/2"	3,700	3,659	175 Sq. Ft.	A8434-11B
A8434G	250					3,456		
A8436N	265	3" M. NPT	17 7/8"	3/4"	10,210	9,839	602 Sq. Ft.	A8436-11B
A8436G	250					9,598		

* Per NFPA Pamphlet #58, Appendix D. Area shown is for UL or ASME flow rating—which ever is larger.

FULLY INTERNAL "POP-ACTION" PRESSURE RELIEF VALVES FOR AUTOGAS CONTAINERS

8543 Series relief valves are designed for use as a primary relief valve in larger ASME Autogas containers such as on buses, trucks and construction equipment. 8544 Series relief valves are designed for use as a primary relief valve in smaller ASME and DOT Autogas containers such as on tractors, lift trucks, cars and taxicabs.



8544 Series



7543-10



7544-11A

Part no.	Container Type	Start to Discharge Setting (PSIG)	Container Connection M. NPT	Overall Height (approx.)	Height Above Coupling (approx.)	Hex Wrenching Section	Flow Capacity SCFM / Air***		Protective Cap Included	Accessories
							UL (at 120% of Set Pressure)	ASME (at 120% of Set Pressure)		Pipeaway Adapter
8544G	ASME	250	1"	5 7/16"	7/8"	1 5/16"	1,020	936	7544-41G	7544-11A*
8543G			1 1/4"			1,465	1,400	3131-41	7543-10**	
8544T		1"	1,282			1,158	7544-41	7544-11A*		
8543T		1 1/4"	1,990			1,731	3131-41	7543-10**		
8544K	DOT / ASME	375	1"			1 5/16"	1,545***	—	7544-41	7544-11A*

* 1" M. NPT outlet connection. ** 1 1/4" M. NPT outlet connection. *** Rating also applies to DOT requirements. **** Flow rates shown are for bare relief valves. Adapters and pipeaway will reduce flow as discussed in forewording information.

FULLY INTERNAL "POP-ACTION" ASME 3/4" PRESSURE RELIEF VALVES FOR MOTOR FUEL CONTAINERS

Designed for use as a primary relief valve in ASME RV & small engine containers. Assures Minimum product loss due to "pop-action" design. Recessed design minimizes possibility due to damage and tampering. Threaded to accept Rego® Pipeaway Adapter that permits the addition of a discharge hose or piping. ASME rated for LP-Gas.

8546-11



8546



Part no.	Container Type	Start to Discharge Setting PSIG	Container Connection MNPT	Overall Height (Approx)	Hex Wrenching Section	Flow Capacity SCFM/Air		Accessories	
						UL (@ 120% of Set Pressure)	ASME (@ 120% of Set Pressure)	Protective Cap (Included)	Pipeaway Adapter
8546G	ASME	250	3/4"	4 1/2"	1 1/16"	723	651	11565-26	8546-11
8546T		312				880	792		



Non-stock/special order items are not cancellable or returnable

Shop online at www.raymurray.com or call **800-628-5044**

Pressure Relief Valves



FULLY INTERNAL "POP-ACTION" PRESSURE RELIEF VALVES FOR DOT FORKLIFT CYLINDERS

Designed specifically for use as a primary relief valve on forklift cylinders, the 8545AK reduces the possibility of improper functioning of the relief mechanism due to foreign material build up. All guides, springs, stem and adjusting components are located inside the cylinder - removed from the direct exposure of foreign materials and debris from the atmosphere.

NFPA Pamphlet #58 requires that: "All containers used in industrial truck (including forklift truck cylinders) service shall have the container pressure relief valve replaced by a new or unused valve within 12 years of the date of manufacture of the container and each 10 years thereafter."

Part no.	Container Type	Start to Discharge Setting (PSIG)	Container Connection M. NPT	Flow Capacity SCFM / Air** (ECII Rated at 480 PSIG)
8545AK	DOT	375	3/4"	400*

Accessories (Order Separately)		Part no.
Protective Cap (Included)		7545-40
Deflectors***	45° Elbow	7545-14*
	90° Elbow	7545-12
Orange Cap		11557-19

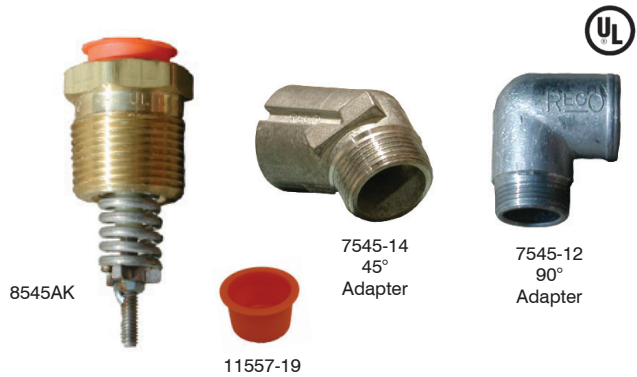

* Classified by U.L. in accordance with Compressed Gas Association Pamphlet S-1.1 Pressure Device Standards for Cylinders. Meets requirements for use on DOT containers with 262 pounds or less weight of water or 109 pounds or less of LP-Gas.** Flow rates are shown for bare relief valves. Adapters and pipeways will reduce flow. *** Order protective cap #8545-41 or 7545-40.

SEMI-INTERNAL "POP-ACTION" PRESSURE RELIEF VALVES FOR ASME CONTAINERS

Designed for use as a primary relief valve on ASME containers such as 250, 500 and 1,000 gallon tanks. Underwriters' Laboratories lists containers systems on which these types of valves are mounted outside the hood without additional protection, if mounted near the hood and fitted with a protective cap.



8684 Series

Part no.	Start to Discharge Setting (PSIG)	Container Connection M. NPT	Overall Height (approx.)	Height Above Coupling (approx.)	Wrench Hex Section	Flow Capacity SCFM / Air		Suitable for Tanks with Surface Area Up to:*	Protective Cap (Included)
						UL (at 120% of Set Pressure)	ASME (at 120% of Set Pressure)		
7583G	250	3/4"	8 3/16"	1 7/16"	1 3/4"	1,980	1,806	80 Sq. Ft.	7583-40X
8684G		1"	9 3/8"	1 9/16"	1 7/8"	2,620	2,565	113 Sq. Ft.	8684-40
8685G		1 1/4"	11 1/16"	1 11/16"	2 3/8"	4,385	4,035	212 Sq. Ft.	7585-40X

* Per NFPA Pamphlet #58, Appendix D. Area shown is for UL or ASME flow rating—whichever is larger.



SEMI-INTERNAL "POP-ACTION" PRESSURE RELIEF VALVES FOR LARGE STORAGE CONTAINERS

Designed especially for use as a primary relief valve on large stationary storage containers, these low profile relief valves are generally mounted in half couplings. However, they are designed so that the inlet ports clear the bottom of a full 2" coupling. This assures that the relief valve should always be capable of maximum flow under emergency conditions.

Part no.	Start to Discharge Setting (PSIG)	Container Connection M. NPT	Flow Capacity SCFM / Air*		Suitable for Tanks w/ Surface Area Up to:**	Accessories	
			UL (at 120% of Set Pressure)	ASME (at 120% of Set Pressure)		Protective Cap	Pipeway Adapter
7534B	125	2"	6,025	—	319 Sq. Ft.	7534-40X	7534-20***
7534G	250		11,675	10,422	708 Sq. Ft.		



* Flow rates are shown for bare relief valves. Adapters and pipeways will reduce flow. **Per NFPA Pamphlet #58, Appendix D. Area shown is for UL or ASME flow rating—whichever is larger. ***3" FNPT outlet connection.



Non-stock/special order items are not cancellable or returnable

Shop online at www.raymurray.com or call 800-628-5044

Pressure Relief Valves

EXTERNAL POP-ACTION PRESSURE RELIEF VALVES FOR ACME CONTAINERS & BULK PLANT INSTALLATIONS

Designed especially for use as a primary relief valve on large stationary storage containers, these low profile relief valves are generally mounted in half couplings. However, they are designed so that the inlet ports clear the bottom of a full 2" coupling. This assures that the relief valve should always be capable of maximum flow under emergency conditions.

Note: Parts that begin with AA are NOT for use with Propane.



Part no.	Start to Discharge Setting (PSIG)	Container Connection M. NPT	Overall Height (approx.)	Hex Wrenching Section	Flow Capacity SCFM / Air (a)			Suitable for Tanks w/ Surface Area Up to: (Sq. Ft.) (e)	Accessories			
					UL (at 120% of Set Pressure)	ASME (at 120% of Set Pressure)	Protective Cap Part no.		Pipeaway Adapter		Weep Hole Deflector	
									Part no.	Outlet Size		
AA3126L030	30	1/2"	2 3/8"	7/8"	(c)	—	—	9103-54	AA3126-10	1/2" M. NPT	—	
AA3126L250					277 (c)	—	23 (f)	9103-54	AA3126-10			
3131G	250	3/4"	3 7/16"	1 3/4"	2,060	1,939	85	3131-41	(g)	3131-10		—
AA3130UA250					2,045	1,838	249 (f)	11557-110		AA3131-10	1" F. NPT	
W3132G		1"	6 1/32"	2 3/8"	3,340	—	154	3132-54	(g)	3132-10	1 1/4" F. NPT	3133-11
3132G					4,130	—	200			—	—	
T3132G		3,790	—	180	3132-10	1 1/4" F. NPT						
MV3132G		3,995	—	190	—	—						
3135G		5 21/32"	2 11/16"	5,770	—	300	3135-54	(g)	3135-10	2" F. NPT	—	
AA3135UA250												6 13/32"
3133G		1 1/2"	5 15/16"	3 1/8"	6,080	—	320	3133-54	(g)	3133-10	—	
A3149G		2 1/2"	10 1/2"	4 1/8"	10,390	9,153	613	3149-40		(h)	Included (j)	
AA3130UA265	265	3/4"	3 7/16"	1 3/4"	2,125	1,912	261 (f)	11557-110	AA3131-10	1" F. NPT	—	
AA3135UA265		1 1/4"	6 13/32"	2 11/16"	6,615	5,370 (d)	1,045 (f)	AA3135-40PR	AA3135-10	2" F. NPT	3133-11	
AA3126L312	312	1/2"	2 3/8"	7 1/8"	330 (c)	—	27 (f)	9103-54	AA3126-10	1/2" M. NPT	—	

(a) Flow rates shown are for bare relief valves. Adapters and pipeaways will reduce flow as discussed in forewording information.

(b) Not UL or ASME rated. .059 square inch effective area.

(c) Not UL or ASME rated. RegO® rated at 120% of set pressure.

(d) Rated at 110% of set pressure.

(e) Per NFPA Pamphlet #58, Appendix D. Area shown is for UL or ASME flow rating— whichever is larger.

(f) Per ANSI K61.1-1972, Appendix A. (g) Cap supplied with chain. (h) Outlet 312-8N (F) thread, will accept 3" M. NPT pipe thread. (j) Weep hole defectors Part No. A3134-11B.



Pressure Relief Valves



EXTERNAL HYDROSTATIC RELIEF VALVES

Designed especially for the protection of piping and shut-off valves where there is a possibility of trapping liquid LP-Gas or anhydrous ammonia. May be installed in pipelines and hoses located between shut-off valves or in the side boss of RegO® shut-off valves.

Part no.	Start to Discharge Setting (PSIG)	Valve Body Material	Container Connection M. NPT	Height (approx.)	Wrench Hex Section	Accessories		
						Protective Cap	Pipeaway Adapter or Threads	
SS8001G	250	Stainless Steel	1/4"	7/8"	11/16"	8001-55	—	
SS8002G			1/2"		7/8"	8022-54		
SS8021G			1/4"	1 3/8"	11/16"	8001-55	1/4" NPSM Thrds.	
SS8022G			1/2"		7/8"	8022-54	3/8" NPT Thrds.	
3127G			1/4"		1 31/32"	7/8"	9103-54	—
3129G	275	Brass	1/2"	2 19/32"	1 1/8"	3129-40P	3129-10*	
3127H			1/4"	1 31/32"	7/8"	9103-54	—	
3129H			1/2"	2 19/32"	1 1/8"	3129-40P	3129-10*	
3127P			300	1/4"	1 31/32"	7/8"	9103-54	—
3129P				1/2"	2 19/32"	1 1/8"	3129-40P	3129-10*
3127J	350	Stainless Steel	1/4"	1 31/32"	7/8"	9103-54	—	
3129J			1/2"	2 19/32"	1 1/8"	3129-40P	3129-10*	
SS8001J			1/4"	7/8"	11/16"	8001-55	—	
SS8002J			1/2"		7/8"	8022-54		
SS8021J			1/4"	1 3/8"	11/16"	8001-55	1/4" NPSM Thrds.	
SS8022J	1/2"		7/8"	8022-54	3/8" NPT Thrds.			
3127K	375	Brass	1/4"	1 31/32"		9103-54	—	
3129K			1/2"	2 19/32"	1 1/8"	3129-40P	3129-10*	
3125L	400	Brass	1/4"	1 9/16"	5/8"	3125-40P Included	—	
3127L				1 31/32"	7/8"	9103-54		
3129L			1/2"	2 19/32"	1 1/8"	3129-40P	3129-10*	
SS8001L		Stainless Steel	1/4"	7/8"	11/16"	8001-55	—	
SS8002L			1/2"		7/8"	8022-54		
SS8021L	1/4"		1 3/8"	11/16"	8001-55	1/4" NPSM Thrds.		
SS8022L	1/2"		7/8"	8022-54	3/8" NPT Thrds.			
3127U	450	Brass	1/4"	1 31/32"		9103-54	—	
3129U			1/2"	2 19/32"	1 1/8"	3129-40P	3129-10*	
SS8001U		Stainless Steel	1/4"	7/8"	11/16"	8001-55	—	
SS8002U			1/2"		7/8"	8022-54		
SS8021U			1/4"	1 3/8"	11/16"	8001-55	1/4" NPSM Thrds.	
SS8022U	1/2"	7/8"	8022-54		3/8" NPT Thrds.			

31257 Series



SS8022G



* 12" F. NPT outlet connection.



Non-stock/special order items are not cancellable or returnable

Pressure Relief Valves

EXTERNAL POP-ACTION SUPPLEMENTARY PRESSURE RELIEF VALVES - SMALL ASME & DOT CYLINDERS

Designed for use as a supplementary relief valve on small ASME above ground and under-ground containers. They may also be used as a primary or secondary relief device on DOT cylinders, or as hydrostatic relief valves. All working components of these relief valves are outside the container connection, so the valves must be protected from physical damage.



Part no.	Container Type	Start to Discharge Setting (PSIG)	Container Connection M. NPT	Overall Height (approx.)	Wrench Hex Section	Flow Capacity SCFM / Air*		Suitable for Tanks w/ Surface Area Up to: ***	Accessories		
						UL (at 120% of Set Pressure)	(ECII Rated at 480 PSIG)**		Protective Cap	Pipeaway Adapter	
										Part no.	Outlet Size
3127G	ASME	250	1/4"	1 31/32"	7/8"	295	—	—	9103-54	—	
3129G			1/2"	2 19/32"	1 1/8"	465	—	—	3129-40P	3129-10 1/2" F. NPT	
3127K	DOT	375	1/4"	1 31/32"	7/8"	—	450	100 lbs. Propane	9103-54	—	
3129K			1/2"	2 19/32"	1 1/8"	—	780	200 lbs. Propane	3129-40P	3129-10 1/2" F. NPT	

* Flow rates shown are for bare relief valves. Adapters and pipeaways will reduce flow as discussed in forewording information.
 ** Not UL or ASME rated. RegO® rated at 480 PSIG.
 *** Meets DOT requirements.

DUOPORT PRESSURE RELIEF VALVE MANIFOLDS FOR SMALL STORAGE CONTAINERS

Designed especially for use as a primary relief device on smaller stationary storage containers, with 2" NPT threaded couplings. These manifolds allow servicing or replacement of either of the two relief valves without evacuating the container or loss of service. The operating lever selectively closes off the entrance port to the relief valve being removed while the remaining valve provides protection for the container and its contents. The rating of each manifold is based on actual flow through the manifold and a single pressure relief valve, taking friction loss into account. It is not merely the rating of the relief valve alone.

Note: Parts that begin with AA are NOT for use with Propane.



Part no.	Start to Discharge Setting (PSIG)	Application		Container Connection M. NPT	Relief Valve Included			Flow Capacity SCFM / Air**		
		LP-Gas	NH ₃		Quantity	Part no.	Inlet Connection M. NPT	Pipeaway Adapters	UL Rating (at 120% of Set Pressure)	ASME Rating (at 120% of Set Pressure)
8542G	250	Yes	No	2"	2	3135MG	1 1/4"	3135-10*	5,250 (1)	NA
8542AG									NA	53,45 (1)
AA8542UA250		No	Yes						AA3135MUA250	AA3135MUA265
AA8542UA265	265			6,615 (1)	6,404 (1)					

* 2" F. NPT outlet connection.
 ** Flow rating based on number of relief valves indicated in parenthesis (). Flow rates shown are for bare relief valves. Adapters and pipeaways will reduce flow rates as discussed in L-102 catalog forewording information.



Pressure Relief Valves



MULTIPOINT PRESSURE RELIEF VALVE MANIFOLD ASSEMBLIES FOR LARGE STORAGE CONTAINERS

Designed for use as a primary relief device on large stationary pressurized storage containers with flanged openings. These manifolds incorporate an additional relief valve, not included in the flow rating, allowing for servicing or replacement of any one of the relief valves without evacuating the container. Handwheel on manifold selectively closes off entrance port to the relief valve being removed while remaining relief valves provide protection for the container and its contents. All manifold flow ratings are based on flow through the relief valves after one has been removed for service or replacement.

Johns-Manville Spirotallic flange gasket furnished with each manifold assembly.



A8574G

Bolt studs and nuts

Part no.	Consists of:	For Use with:	For Connection to:	Number Required
7560-55	1- Bolt Stud and Nut	All RegO Multiports	Modified 3" - 300# and 4" - ASA 300# Welding Neck Flange	8
7560-56			Manhole Cover Plate	

Bleeder Valve Assembly

Part no.	Description
8560-26TP	Bleeder Valve Assembly

Multiport manifold assemblies

Part no.	Start to Discharge Setting PSIG	Application		Container Flange Connection	Relief Valve Included			Accessories	Flow Capacity SCFM / Air** at 120% of Set Pressure	
		LP-Gas	NH ₃		Qty.	Part no.	Inlet Connection M. NPT		Pipeaway Adapters	UL Rating
A8563G	250	Yes	Yes	3"-300#*	3	A3149MG (must be used in Multiport)	2 1/2"	****	18,500 (2)	Not Applicable
A8564G					4				27,750 (3)	
A8573G					3				18,500 (2)	
A8574G					4				27,750 (3)	
A8563AG				3"-300#*	A3149G (can stand alone)	3			Not Applicable	18,300 (2)
A8564AG						4				27,459 (3)
A8573AG						3				18,300 (2)
A8574AG						4				27,459 (3)

* For use with modified 300# ANSI flange with 4" port. ** Flow rating based on number of relief valves indicated in parenthesis (). Flow rates shown are for bare relief valves. Adapters and pipeaways will reduce flow rates. *** 2" F. NPT outlet connection. **** Outlet 312-8N (F) thread, will accept 3" M. NPT pipe thread.

ASME RATED DELTA PORT RELIEF VALVE MANIFOLDS

Designed especially for use as a primary relief device on large stationary pressurized storage containers, the base is supplied with a two-inch NPT threaded container connection. These manifolds incorporate an additional relief valve, not included in the flow rating, allowing for servicing or replacement of any one of the relief valves without evacuating the container. The hand-wheel on the manifold selectively closes off the entrance port to the relief valve being removed while the remaining relief valves provide protection for the container and its contents. All manifold flow ratings are based on flow through the relief valves after one has been removed for service or replacement.



Part no.	Start to Discharge Setting PSIG**	Application	Container Connection M-NPTF	Relief Valve				ASME Rating SCFM (air) @ 120% of Set Pressure*
				Qty	Item #	Inlet Connection M-NPT	Accessories: Pipe-away Adapter***	
8532AG	250	LPG	2"	2	3135MG	1 1/4"	3135-10	5,345 (1)
8533AG				3				10,690 (2)
AA8532MA250				2				AA3135MA250
AA8533MA250	3	12,116 (2)						
AA8532MA265	265	NH ₃		2	6,404 (1)			
AA8533MA265				3	12,808 (1)			

* Flow rating based on number of relief valves indicated in parenthesis (). Flow rates shown are for bare relief valves. Adapters and pipeaways will reduce flow rates. **Other pressure settings available. *** 2" F. NPT outlet connection on adapters.



Non-stock/special order items are not cancellable or returnable

Globe and Angle Valves

V-RING SEAL GLOBE & ANGLE VALVES - BULK STORAGE CONTAINERS, TRANSPORTS, BOBTAILS, PLANTS

Specifically designed to assure positive shut-off and long, maintenance free service life in liquid or vapor service on bulk storage containers, transports, bobtails, cylinder filling plants and plant piping. The high quality construction and wide variety of sizes make them highly suited for use with LP-Gas, anhydrous ammonia and in the chemical and petro-chemical industries.



Part no.						Inlet and Outlet Connection	Port Diameter	Flow at 1 PSIG Pressure Drop (Cv) (GPM/Propane)***		Accessories	
Buna N Seat Discs		Teflon Seat Discs*		Synthetic Rubber Seat Discs****				Globe	Angle	Hydrostatic Relief Valve	Vent Valve
Globe	Angle	Globe	Angle	Globe	Angle						
—	—	TA7034P	TA7034LP	—	—	1/2" F. NPT	3/4"	10	14.8	SS8001U	TSS3169
A7505AP	A7506AP	TA7505AP	TA7506AP	—	—	3/4" F. NPT		12	17.7		
A7507AP	A7508AP	TA7507AP	—	—	—	1" F. NPT	1"	17.8	22		
A7509BP	A7510BP	TA7509BP	TA7510BP	—	—	1 1/4" F. NPT	1 1/4"	36.5	54		
A7511AP	A7512AP	TA7511AP	TA7512AP	—	—	1 1/2" F. NPT	1 1/2"	43	55.5		
A7511FP	—	TA7511FP	—	—	—	1 1/2" Flange**		46	—		
A7513AP	A7514AP	TA7513AP	—	—	—	2" F. NPT	2"	75	88.5		
—	—	—	—	HA7513AP	HA7514AP			—	—		
A7513FP	A7514FP	TA7513FP	TA7514FP	—	—	2" Flange**	78	133			
A7517AP	A7518AP	TA7517AP	—	—	—	3" F. NPT	3 1/8"	197	303		
A7517FP	A7518FP	TA7517FP	—	—	—	3" Flange**				—	—
—	—	—	—	HA7517AP	HA7518AP	3" F. NPT				3 1/2"	—

* Teflon seat discs on valves built to order. ** 300# ANSI R.F. Flange. *** To obtain approximate flow at other than 1 PSIG pressure drop, multiply flow in chart by square root of pressure drop. Example: 7514FP @ 9 PSIG = 133 x square root of 9 = 399 GPM/propane. For NH3 flow, multiply propane flow by .90. **** HA75 Series designed for use in conjunction with Rego 6588LE & 6589LE Low Emission Filler Valves installed on bobtails and transports.



Globe & Angle Valves



QUICK ACTING MINIMUM LOSS HOSE END VALVES BOBTAIL DELIVERY TRUCKS & DISPENSING STATIONS

Designed to vastly reduce the amount of product vented when disconnecting bobtail delivery trucks, dispensing systems and anhydrous ammonia nurse tanks. Provide instant, full-on flow at the flip of a handle. Shut-off is instant and handle locks for added protection. This "top of the line" hose-end valve is a fully contained unit that does not require additional filling adapters or connectors.

Part no.	Inlet Connection (F. NPT)	Outlet Connection (F. ACME)	Locking Handle	Flow at 1 PSIG (Cv) Pressure Drop* (GPM/Propane)
A7793A	3/4"	1 3/4"	Yes	16
A7797A	1"	1 3/4"	Yes	16

* To obtain approximate flow at other than 1 PSIG pressure drop, multiply flow in table by square root of pressure drop. Example: A7797 @ 9 PSIG = 16.0 x square root of 9 = 48.0 GPM/propane. For NH3 flow, multiply propane flow by .90.

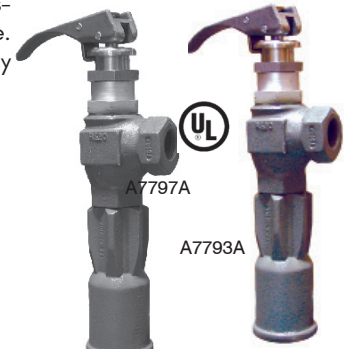

QUICK ACTING HOSE END VALVES FOR BOBTAIL DELIVERY TRUCKS AND DISPENSING STATIONS

Designed especially for safe operator handling of LP-Gas in bobtail delivery truck, dispensing systems and anhydrous ammonia nurse tank service. These valves provide instant, full-on flow at the flip of the handle and provide instant positive shut-off with a handle lock for added protection.

Part no.	Body Design	Inlet & Outlet Connection (F. NPT)	Locking Handle	Flow at 1 PSIG (Cv) Pressure Drop* (GPM/Propane)	Accessories		
					Filling Connectors**		
					Extended Steel	Brass	Compact Steel
A7707L	Straight	1"	Yes	18	A7575L4	3175A	A3175A
A7708L	Angle			22			

* To obtain approximate flow at other than 1 PSIG pressure drop, multiply flow in table by square root of pressure drop. Example: A7708L @ 9 PSIG = 22.0 x square root of 9 = 66.0 GPM/propane. For NH3 flow, multiply propane flow by .90. ** See appropriate L-500 catalog section for additional information.

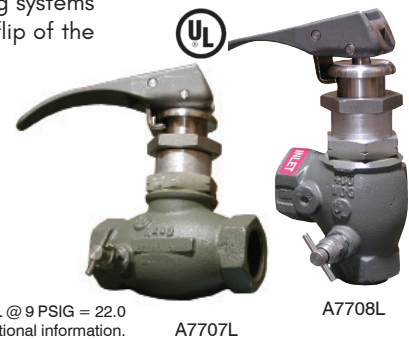

2" FNPT X 3 1/4" ACME LOW EMISSION HOSE END VALVE FOR LOADING BOBTAILS & TRANSPORTS

Minimum loss valve designed to reduce the amount of product vented when disconnecting bobtail and transport loading hoses. Provides a full-on flow when pressing the release trigger and lifting an easy grip handle. Lowering the handle will immediately stop flow and lock the lever in the closed position. Designed to be used with RegO 6588LE and 6589LE 3" M-ACME minimum loss filler valves but can be used with any standard 3" Male ACME connector. Complies to CARB regulations. **Discharges less than 2 CCs at disconnect.** Contoured handle rotates 360° large, easy to turn ACME swivel connector. Self-locking handle is operator opened and closed designed to prevent accidental opening of the valve. Bypass mechanism in the seat area allows the upstream pressure to quickly equalize when the handle is partially moved to the open position. Spring loaded Teflon "V" packing for bonnet/stem assembly provides long service life.

Part no.	Inlet Connection	Outlet Connection	Locking Handle	Flow at (Cv) Pressure Drop* GPM Propane	
				1 PSIG	10 PSIG
A7914A	2" FNPT	3 1/4" M. ACME	Yes	55	174

*To obtain approximate flow at other than 1 PSIG drop, multiply flow in table by square root of pressure drop. Example A7914A @ 9 PSIG drop = 55 X √9 = 165 GPM /propane



1 1/2" ANGLE VALVE WITH EXCESS FLOW FOR NH3

Designed especially for use as a high capacity liquid withdrawal valve on Anhydrous Ammonia containers. Incorporates an integral excess flow valve. Designed for high flow and low pressure drop. Excess flow seat fully contained in container coupling for maximum protection in the event of external damage to valve. V-ring spring loaded stem seal design requires no field adjustment. " F-NPT port accommodates a vent valve or hydrostatic relief valve. UL Listed.

Part no.	Inlet Connection (M.NPT)	Outlet Connection (F.NPT)	Approximate Closing Flow NH3*	Accessories for NH3 Use	
				Hydrostatic Relief Valve	Vent Valve
A8012D	1 1/2"	1 1/4"	72 GPM	SS8001J	TSS3169
A8012C			45 GPM	SS8001J	TSS3169

* When installed in a horizontally flowing system.



Globe & Angle Valves

FLANGE SEAL GLOBE & ANGLE VALVES FOR BULK STORAGE CONTAINERS, FILLING HOSES & PLANT PIPING

Designed to assure positive shut-off and long maintenance-free service life in liquid or vapor service. Ideally suited for use on cylinder charging manifolds, truck filling hoses, bulk storage containers and plant piping. The high quality construction and wide variety of sizes make them highly suited for use with LP-Gas, anhydrous ammonia and in the chemical and petrochemical industries.

Part no.		Inlet & Outlet Connection (F. NPT)	Flow at 1 PSIG (Cv) Pressure Drop (GPM/Propane)*		Accessories	
Globe	Angle		Globe	Angle	Hydrostatic Relief Valve	Vent Valve
7704P	7704LP	1/2"	7.3	12.3	SS8001J or SS8001L	TSS3169
A7704P	A7704LP					
7705P	7706P	3/4"	11.5	17.7		
A7705P	A7706P					

* To obtain approximate flow at other than 1 PSIG pressure drop, multiply flow in table by square root of pressure drop. Example: A7704LP @ 9 PSIG = 12.3 x square root of 9 = 36.9 GPM/propane. For NH3 flow, multiply propane flow by .90.

FLANGE SEAL LIQUID TRANSFER ANGLE VALVES FOR BULK STORAGE CONTAINERS

Designed especially for liquid transfer of LP-Gas from consumer bulk storage containers when used with a Chek-Lok® or equipped with an integral excess flow valve. May also be used for vapor LP-Gas service. In NH3 applicator tanks they may be used as a vapor bleeder valve or as a liquid withdrawal valve when installed in a coupling with a dip pipe. These valves are equipped with an integral excess flow valve for liquid transfer directly from the tank fitting, or without an integral excess flow for LP-Gas transfer through a Check-Lok®. When equipped with an integral excess flow valve (7550PX), the valve should be mounted in a forged steel 3000 lb. half coupling. When mounted in a 1" x 3/4" NPT reducing coupling, the 3/4" female thread in this coupling must be full length - equivalent to a forged steel 3000 lb. half coupling. *The excess flow valve will not function properly if these specifications are not met.*

Part no.	Inlet Connection (M. NPT)	Outlet Connection (F. NPT)	Integral Excess Flow	Flow at 1 PSIG (Cv) Pressure Drop* (GPM/Propane)	Excess Flow Approximate Closing Flow (GPM/Propane)**	Accessories	
						Hydrostatic Relief Valve	Vent Valve
7550P	3/4"	3/4"	No	13.3	—	3127U	3165C
A7550P			SS8001J			TSS3169	
7550PX		Yes	16	3127U	3165C		
A7550PX		SS8001J		TSS3169			
7551P	1/2"	1/2"	No	8.9	—	3127U	3165C
A7551P			SS8001J			TSS3169	

* To obtain approximate flow at other than 1 PSIG pressure drop, multiply flow in table by square root of pressure drop. Example: 7550P @ 9 PSIG = 13.3 x square root of 9 = 39.9 GPM/propane. For NH3 flow, multiple propane flow by .90. ** For NH3 flow, multiply propane flow by .90.

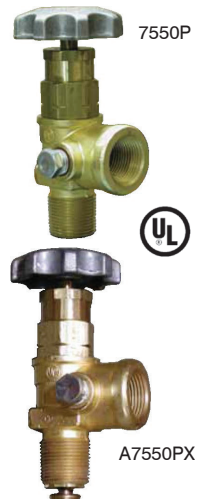
QUICK ACTING VALVES FOR CYLINDER CHARGING HOSES

Designed primarily for use on cylinder charging hoses to provide fast, convenient shut-off and fast opening. These valves must be installed so that flow through the valve is in the opposite direction to that of a conventional globe valve. This allows the inlet flow to assist in closing the valve, and even more important, helps prevent the valve from being forced open by high pump pressure.

Part no.	Inlet Connection (F. NPT)	Outlet Connection (F. NPT)	Body Material	Flow at 1 PSIG (Cv) Pressure Drop* (GPM/Propane)
7901T	1/4"	1/4"	Brass	1.95
A7553A			Ductile Iron	
7901TA	3/8"	3/8"	Brass	
7901TB	1/2"	1/4"		
7901TC		1/2"		

* To obtain approximate flow at other than 1 PSIG pressure drop, multiply flow in table by square root of pressure drop. Example: 7901T @ 9 PSIG = 1.95 x square root of 9 = 5.85 GPM/propane. For NH3 flow, multiply propane flow by .90.

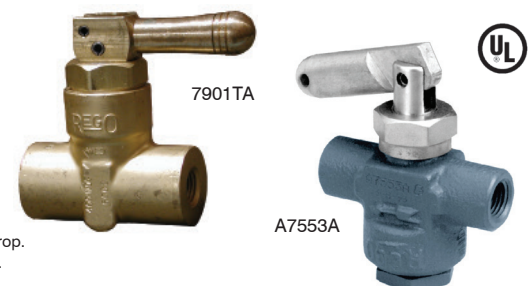

Globe & Angle Valves



QUICK ACTING VALVES FOR DISPENSING HOSES

Designed primarily for use on dispensing hoses to provide fast, convenient shut-off and fast opening. These valves feature a locking handle to prevent accidental opening of the handle if it were dropped.

Features • Quick-acting design speeds transfer operations. • Permits easy, one-handed opening and closing of the valve. • O-ring stem seal design. • Provides quick, positive shut-off. • Safety lock prevents accidents.

Part no.	Inlet Connection (F.NPT)	Outlet Connection (F. NPT)	Body Material	Flow at 1 PSIG (CV) Pressure Drop* (GPM/Propane)
7901TLA	3/8"	3/8"	Brass	1.95
7901TLB	1/2"	1/4"		
7901TLC		1/2"		

* To obtain approximate flow at other than 1 PSIG pressure drop, multiply flow in table by square root of pressure drop. Example: 7901T @ 9 PSIG = 1.95 x 9 = 5.85 GPM/propane. For NH3 flow, multiply propane flow by .90.



QUICK ACTING VALVES FOR CROP DRYERS AND CHARGING MANIFOLD HOSES

7554S Series valves provide instant shut-off and fast opening control on LP-Gas crop driers. They are also ideal for charging manifold hoses, stationary fuel transfer hoses and other applications requiring quick, positive shut-off. Not for use with delivery truck hoses because the handle could snag on the ground and open the valve as the hose is reeled back to the truck. 7554L Series valves feature a locking handle device to help prevent accidental opening of the valve. It is ideal for all the same applications as the 7554S Series and may be used on delivery trucks as it incorporates the locking handle design. Both valve series must be installed so that flow through the valve is opposite to that of a conventional globe valve. This allows the inlet flow to assist in closing the valve and prevents the valve from being opened by high pump pressures.

Part no.	Inlet Connection (F. NPT)	Locking Handle	Flow at 1 PSIG (Cv) Pressure Drop* (GPM/Propane)
7554SAV	1/2"	No	7.3
7554LAV		Yes	
7554SV	3/4"	No	11.5
7554LV		Yes	

To obtain approximate flow at other than 1 PSIG pressure drop, multiply flow in table by square root of pressure drop. Example: 7554LV @ 9 PSIG = 11.5 X square root of 9 = 34.5 GPM/propane.



MULTIPURPOSE VALVE FOR FILLING OF NH₃ CONTAINERS

Designed specifically for use as a manual filler valve on anhydrous ammonia applicator and nurse tanks. This valve incorporates an integral back check valve.

Part no.	Inlet Connection (M.NPT)	Filling Connection (M. ACME)	Filling Capacity at 20 PSIG Pressure Drop GPM/NH ₃	Accessories	
				Hydrostatic Relief Valves	Vent Valve
A8016DBC	1 1/4"	1 1/4"	95	SS8001J	TSS3169



MULTIPURPOSE VALVE FOR NH₃ CONTAINERS

Designed specifically for use on NH₃ applicator and nurse tanks. Incorporates an integral excess flow valve. When product is required, the valve must be completely open and backseated to allow the excess flow valve to function properly as explained in the excess flow valve section of the RegO L-500 catalog.

Part no.	Inlet Connection (M.NPT)	Filling Connection (M. ACME)	Filling Capacity at 20 PSIG Pressure Drop GPM/NH ₃	Approximate Excess Flow Closing Flows		Accessories	
				Liquid* GPM/NH ₃	Vapor** CFH/NH ₃	Hydrostatic Relief Valves	Vent Valve
A8016DP	1 1/4"	1 3/4"	95	44	24,000	SS8001J	TSS3169

* Determined at 9.5 to 12 PSIG differential. ** Determined at 100 PSIG inlet.



Globe & Angle Valves

MULTIPURPOSE VALVES FOR LIQUID WITHDRAWAL OF LP-GAS AND NH₃ CONTAINERS

Designed especially for use as a high capacity liquid withdrawal valve on LP-Gas and anhydrous ammonia containers. These valves incorporate an integral excess flow valve. When product is required, the valve must be completely open and backseated to allow the excess flow valve to function properly as explained in the excess flow valve section of this catalog. The A8017DH is equipped with a soft seated automatic differential back pressure check valve in the seat disc assembly. This allows any pressure build up in the liquid transfer line in excess of 10-15 psig above the container pressure to flow back into the container. The transfer hose is protected against excessive liquid or vapor pressure entrapment, which adds materially to the useful life of flexible hose. In addition to increasing hose service life, the equalizing valve adds substantially to the operating safety of liquid transfer systems.

Part no.	Inlet Connection (M.NPT)	Outlet Connection (M.NPT)	Approximate Excess Flow Liquid Closing Flows** (GPM/Propane)	Accessories	
				Hydrostatic Relief Valves	Vent Valve
A8017DH*	1 1/4"	1"	49	Not Required	TSS3169
A8017DP		3/4"	55	SS8001J	
A8017DLP			49		

* Built-in back pressure check valve incorporated into shut-off valve.

** Determined at 11.5 to 13.5 PSIG differential for 3/4" outlet and 9 to 12 PSIG differential for 1" outlet. For NH₃ flow, multiply by .90.



A8017D

MULTIPURPOSE VALVE FOR FILLING AND LIQUID TRANSFER OF NH₃ CONTAINERS

Designed primarily for use as a combination filler and liquid withdrawal valve on three-opening applicator tanks or on nurse tanks. This valve incorporates an integral excess flow valve. When product is required, the valve must be completely open and backseated to allow the excess flow valve to function properly as explained in the excess flow valve section of the Rego L-500 catalog.

Part no.	Inlet Connection (M.NPT)	Outlet Connection (F. NPT)	Filling Connection (M. ACME)	Filling Capacity at 20 PSIG Pressure Drop GPM/NH ₃	Approximate Excess Flow Liquid Closing Flow GPM/NH ₃ *	Accessories	
						Hydrostatic Relief Valve	Vent Valve
A8018DP	1 1/4"	1"	1 1/4"	74	50	SS8001J	TSS3169

* Determined at 9 to 12 PSIG differential.



A8018DP

MULTIPURPOSE RIGHT ANGLE VALVE FOR LIQUID OR VAPOR SERVICE IN LP-GAS AND NH₃ SYSTEMS

Designed especially for use as a high capacity liquid withdrawal valve in LP-Gas and NH₃ systems. Valve may be mounted directly in nurse tank load-out risers eliminating the need for a separate excess flow valve and angle valve. This valve incorporates an integral excess flow valve. When product is required, the valve must be completely open and backseated to allow the excess flow valve to function properly as explained in the excess flow valve section of this catalog.

Part no.	Inlet Connection (M.NPT)	Outlet Connection (F. NPT)	Filling Connection (M. ACME)	Approximate Excess Flow Liquid Closing Flows*		Accessories	
				GPM/Propane	GPM/NH ₃	Hydrostatic Relief Valve	Vent Valve
A8020D	1 1/4"	1"	1 1/4"	78	24,000	SS8001J	TSS3169

* Determined at 13 PSIG differential.



A8020D



Non-stock/special order items are not cancellable or returnable

Shop online at www.raymurray.com or call **800-628-5044**

Excess Flow Valves



EXCESS FLOW VALVES FOR LIQUID OR VAPOR SERVICE

Designed for top mounting in storage tank manhole covers for liquid or vapor applications. The tapped inlet allows for an optional 1" NPT dip pipe connection to withdraw liquid from the top of the tank. The 1519C4 is designed for installation in long line or branch piping applications.

Part no.	Inlet Connection NPT	Outlet Connection F. NPT	Wrench Hex Flats	Approximate Closing Flows**		
				Liquid (GPM/Propane)	Vapor SCFH (Propane)	
					25 PSIG Inlet	100 PSIG Inlet
1519C2	1½" Male*	1"	2¼"	25	5,000	8,800
1519C4	2" Female	2"	3"	170	28,590	48,600

*1" Female Dip Pipe Connection.
 ** Based on horizontal installation of excess flow valve.
 Flows are slightly more when valves are installed with outlet up; slightly less when installed with outlet down.
 NOTE: Multiply flow rate by .94 to determine liquid butane flow.



EXCESS FLOW VALVES FOR LIQUID OR VAPOR LINE SERVICE

Designed for top installation, in any position, in liquid or vapor service lines. They are intended for long lines or branch piping where tank mounted excess flow valves cannot suffice.

Part no.	Brass or Steel	Inlet Connection F. NPT	Outlet Connection F. NPT	Wrench Hex Flats	Approximate Closing Flows*		
					Liquid (GPM/Propane)	Vapor SCFH (Propane)	
						25 PSIG Inlet	100 PSIG Inlet
1519A2	Brass	1"	1"	1¾"	25	5,000	8,800
A1519A2	Steel						
1519A3	Brass	1½"	1½"	2¼"	60	11,500	20,200
1519A4							
A1519A4	Steel	2"	2"	3"	100	19,000	34,500
1519B4	Brass						
A1519B4	Steel						
A1519A6		3"	3"	4"	225	45,000	82,000

* Based on horizontal installation of excess flow valve. Flows are slightly more when valves are installed with outlet up; slightly less when installed with outlet down.
 NOTE: Multiply flow rate by .94 to determine liquid butane flow and by .90 to determine liquid anhydrous ammonia flow.



Excess Flow Valves

EXCESS FLOW VALVES FOR LIQUID OR VAPOR

Designed for liquid or vapor use for filling, withdrawal and vapor equalizing in container or line applications. They are intended for long lines or branch piping where tank-mounted excess flow valves are inadequate.

Part no.	Brass or Steel	Inlet Connection M. NPT	Outlet Connection F. NPT	Wrench Hex Flats	Approximate Closing Flows*			
					Liquid (GPM/Propane)	Vapor SCFH (Propane)		
						25 PSIG Inlet	100 PSIG Inlet	
12472	Brass	3/4"	3/4"	1 3/8"	4	1,050	1,700	
3272E					10	2,100	3,700	
3272F					15	2,800	5,000	
3272G					20	3,700	6,900	
A3272G	Steel	1 1/4"	1 1/4"	2"	29	5,060	10,100	
3272H	Brass				30	5,850	10,000	
3282A					40	7,600	13,600	
3282B					50	9,000	16,300	
3282C	Steel	1 1/2"	1 1/2"	2 1/4"	90	15,200	28,100	
7574	Brass				70	14,000	25,000	
7574L					Steel	75	14,200	24,800
3292A						2"	2"	2 7/8"
A3292A	Brass	122	22,100	37,600				
3292B		Steel						
A3292B								
A3292C	Steel							

* Based on horizontal installation of excess flow valve. Flows are slightly more when valves are installed with outlet up; slightly less when installed with outlet down. NOTE: Multiply flow rate by .94 to determine liquid butane flow and by .90 to determine liquid anhydrous ammonia flow.



3282A

EXCESS FLOW VALVES FOR VAPOR OR LIQUID

Designed especially for filling, withdrawing or vapor equalizing in half and full coupling installations. Ideal for container service where welded-in dip pipes are not provided. For vapor use, mount in the bottom opening with a threaded dip pipe. For liquid use, mount in the top opening with a threaded dip pipe. These may also be installed in pipe lines provided the connection is made to the male inlet thread and not the female dip pipe connection.

Part no.	Inlet Connection M. NPT	Outlet Connection NPT	Wrench Hex Flats	Approximate Closing Flows***		
				Liquid (GPM/Propane)	Vapor SCFH (Propane)	
					25 PSIG Inlet	100 PSIG Inlet
A2137	2"	2" Male and 1 1/4" Female	2 7/16"	50	10,000	17,000
A2137A				70	14,000	25,000
2139	3"	3" Male and 2" Female	3 1/2"	125	26,500	46,000
2139A				160	32,700	57,200

* 1 1/4" FNPT Dip Pipe Connection.

** 2" FNPT Dip Pipe Connection.

*** Based on horizontal installation of excess flow valve. Flows are slightly more when valves are installed with outlet up; slightly less when installed with outlet down. NOTE: Multiply flow rate by .94 to determine liquid butane flow and by .90 to determine liquid anhydrous ammonia flow.



A2137



Non-stock/special order items are not cancellable or returnable

Shop online at www.raymurray.com or call **800-628-5044**

Excess Flow Valves



EXCESS FLOW VALVES FOR CONTAINER SERVICE

Designed for mounting in threaded full or half couplings in container installations. They may be used for filling, withdrawal or vapor equalizing applications. The exceptionally low pressure drop makes them ideal for pump suction lines. If a riser pipe to the vapor space is used with these valves, the minimum inside diameter of the riser pipe must be at least two times the valve thread size in order not to restrict flow to the side inlet ports.

Part no.	For Use with this Type of Coupling	Inlet Connection M. NPT	Outlet Connection NPT	Wrench Hex Flats	Approximate Closing Flows*											
					Liquid (GPM/Propane)	Vapor SCFH (Propane)										
						25 PSIG Inlet	100 PSIG Inlet									
A8523	Half	3/4"	3/4" Male	1 1/8"	15	5,170	8,800									
A8525	Half	1 1/4"	1 1/4" Male	1 3/4"	35	12,540	21,560									
A7537L4	Half	2"	2" Male and 1 1/4" Female	2 5/8"	75	13,000	25,600									
A7537L4F	Full				150	30,500	52,000									
A7537N4	Half							125	25,000	42,500						
A7537N4F	Full							150	30,500	52,000						
A7537P4	Half										200	39,400	68,300			
A7537P4F	Full													250	51,100	88,700
A7539R6	Half	3"	3" Male and 2" Female	3 3/4"	150	32,100	55,500									
A7539R6F	Full				200	39,400	68,300									
A7539T6	Half							250	51,100	88,700						
A7539T6F	Full										500	89,000	154,000			
A7539V6	Half													500	89,000	154,000
A7539V6F	Full															



A7537N4

* Based on horizontal installation of excess flow valve. Flows are slightly more when valves are installed with outlet up; slightly less when installed with outlet down.
NOTE: Multiply flow rate by .94 to determine liquid butane flow and by .90 to determine liquid anhydrous ammonia flow.

EXCESS FLOW VALVES FOR FLANGE MOUNTING IN CONTAINER SERVICE

Designed for mounting in flanged tank connections with internal threads in the bottom of a container. They may be used in filling, withdrawal or vapor equalizing application. They provide high flow capacity with low pressure drop to minimize pump inlet line cavitation. If a riser pipe to the vapor space is used with these excess flow valves, the minimum inside diameter of the riser pipe must be at least two times the valve thread size in order not to restrict flow to the side inlet ports.

Flange mounted excess flow valves are readily accessible for servicing and completely enclosed and protected in event of fire. Because there is no direct connection between external piping and the valve, stresses imposed on piping will not affect the excess flow valve.

Part no.	Inlet Connection M. NPT	For Installation on	Approximate Closing Flows*		
			Liquid (GPM/Propane)	Vapor SCFH (Propane)	
				25 PSIG Inlet	100 PSIG Inlet
A3500L4	2"	Slotted Body	75	13,000	22,500
A3500N4			125	25,000	42,500
A3500P4			150	30,500	52,000
A3500R6	3"		150	32,100	55,500
A3500T6			200	39,400	68,300
A3500V6			250	51,100	88,700
A4500Y8			4"	500	89,000



A3500L4

* Based on horizontal installation of excess flow valve. Flows are slightly more when valves are installed with outlet up; slightly less when installed with outlet down.
NOTE: Multiply flow rate by .94 to determine liquid butane flow and by .90 to determine liquid anhydrous ammonia flow.

Excess Flow Valves

EXCESS FLOW VALVES FOR LIQUID OR VAPOR WITHDRAWAL

These valves are designed for bottom mounting in consumer storage tanks for liquid service. They may also be top mounted for vapor service. These valves are designed especially for use with RegO® globe and angle valves.

Part no.	Inlet Connection M. NPT	Outlet Connection F. NPT	Wrench Hex Flats	Approximate Closing Flows**		
				Liquid (GPM/ Propane)	Vapor SCFH (Propane)	
					25 PSIG Inlet	100 PSIG Inlet
A8013D	1 1/4"	3/4"	1 3/4"	39	8,700	14,700
A8013DA		1"		44		
A8013DB		1 1/4"		55		
2723C	1 1/4"*	3/4"	1 11/16"	20	3,900	6,900

* 3/4" F. NPT Dip Pipe Connection.

** Based on horizontal installation of excess flow valve. Flows are slightly more when valves are installed with outlet up; slightly less when installed with outlet down.

NOTE: Multiply flow rate by .94 to determine liquid butane flow and by .90 to determine liquid anhydrous ammonia flow.

2723C



A8013D

EXCESS FLOW VALVE FOR PRESSURE GAUGES

Designed for container use in pressure gauge installations to minimize excess gas discharge in the event the pressure gauge is sheared. A suitable shut-off valve should be installed between this valve and the pressure gauge to allow convenient gauge replacement.

Part no.	Inlet Connection M. NPT	Outlet Connection F. NPT	Wrench Hex Flats	Approximate Closing Flows*		
				Liquid (GPM/ Propane)	Vapor SCFH (Propane)	
					25 PSIG Inlet	100 PSIG Inlet
2884D	3/4"	1/4"	1 1/16"	n/a	60	110

* Based on horizontal installation of excess flow valve. Flows are slightly more when valves are installed with outlet up; slightly less when installed with outlet down.

NOTE: Multiply flow rate by .94 to determine liquid butane flow.



2884D

EXCESS FLOW VALVE FOR DOT CYLINDERS

Designed for use on portable systems with vapor or liquid including torches, heaters, lead melting burners, tar and asphalt burners, wallpaper steamers and other applications involving portable DOT cylinders. The POL inlet attaches directly to the cylinder valve and the outlet mounts to the regulator.

Part no.	Inlet Connection	Outlet Connection M. NPT	Wrench Hex Flats	Approximate Closing Flows*		
				Liquid (GPM/ Propane)	Vapor SCFH (Propane)	
					25 PSIG Inlet	100 PSIG Inlet
3199W	Male POL	1/4"	7/8"	0.95	265	500

* Based on horizontal installation of excess flow valve. Flows are slightly more when valves are installed with outlet up; slightly less when installed with outlet down.

NOTE: Multiply flow rate by .94 to determine liquid butane flow.



3199W



Check, Filler and Vapor Equalizing Valves



7590U AND 7591U CHEK-LOK VALVES

Designed with unique 1" NPS threads on both Chek-Lok outlet and adapter inlet. This helps prevent activation of the Chek-Lok® without use of the 7590U-10 adapter. Extra strength connection between body and adapter provides increased strength. An o-ring seal on adapter provides a gas tight seal before the adapter opens the equalizing stem. These Chek-Loks® are also designed for use on permanent installations provided the excess flow valve is sized properly for the system and piping. NOTE: In some cases, it may be necessary to use an in-line excess flow valve to protect the downstream piping. This valve is not recommended for use as a liquid source for pumps.



7590U with Cap

Chek-Lok Number	Inlet Connection	Outlet Connection	Body Wrench Hex Flats	Approximate Effective Length	Cap Wrench Hex Flats	Approximate Closing Flows Liquid (GPM/Propane)*
7590U	3/4" M. NPT	1 5/8" UNF	1 3/4"	1 7/16"	1 5/16"	20
7591U	1 1/4" M. NPT		1 3/4"	1 7/8"		35

* Based on horizontal installation of excess flow valve. Flows are slightly more when valves are installed with outlet up, and slightly less when installed with outlet down. Note: Multiply flow rate by .94 to determine liquid butane flow.

UNION STYLE ADAPTERS FOR 7590U AND 7591U

The 7590U-10 adapter must be used to connect to the 7590U and 7591U Chek-Lok. This insures a proper connection to open the check mechanism. A built in nylon gasket provides a gas tight seal.

Adapter Number	Inlet Connection	Outlet Connection	Wrench Hex Flats
7590U-10	1 5/8" UNF	3/4" F. NPT	1 3/4"
7590U-6	O-Ring for 7590U-10		



7590U-10

CHEK-LOK LIQUID EVACUATION ADAPTER FOR 7590U AND 7591U VALVES

Designed specifically for use with RegO 7590U and 7591U Chek-Lok Excess Flow Valves. Adapter's operating handle opens and closes equalizing stem in the Chek-Lok® valve. Eliminates gas flow through Chek-Lok® valve when installing or removing adapter. Use of RegO® adapter ensures proper connections and opening of the check mechanism.



7590U-20

Adapter Number	Inlet Connection	Outlet Connection	Wrench Hex Flats	Approximate Length
7590U-20	1 5/8" UNF	3/4" F. NPT	1 3/4" F. NPT	4 3/16"

ADAPTERS FOR THE 7572FC AND 7580FC

These adapters must be used to connect to the 7572FC and 7580FC Chek-Loks to open the check mechanism properly. A built in nylon gasket provides a gas tight seal.

Adapter Number	Inlet Connection	Outlet Connection	Wrench Hex Flats
7572C-14A	3/4" M. NPT	3/4" F. NPT	1 3/8" F. NPT
7572C-15A		3/4" M. NPT	



7572C-14A



7572C-15A

Liquid Evacuation Adapter

The operating handle opens and closes the equalizing stem in these older style Chek-Lok valves. Designed to eliminate the need for gas flow from the Chek-Lok® when the adapter is installed or removed. A *shutoff valve, such as a full port ball valve must be installed at the outlet of the 7580F-20 adapter.*

Adapter Number	Inlet Connection	Outlet Connection	Wrench Hex Flats
7580F-20	3/4" M. NPT	3/4" F. NPT	1 3/8"



Shown with Check-Lok (not included)

IMPORTANT NOTICE:
The **7572FC** and **7580FC** Chek-Lok Valves were discontinued by RegO effective August 25, 2002 due to changes in UL requirements. The updated features required by UL are already incorporated into the 7590U and 7591U Chek-Loks (shown above). As of that date, the 7572FC and 7580FC Chek-Lok Valves not bearing the UL symbol are not to be installed anywhere in the U.S.



Non-stock/special order items are not cancellable or returnable

Shop online at www.raymurray.com or call **800-628-5044**

Check, Filler and Vapor Equalizing Valves



DOUBLE CHECK FILLER VALVES - GENERAL INFORMATION

RegO® Double-Check Filler Valves incorporate a resilient upper check valve, normally designated as a filler valve, and a lower check valve, commonly called a back pressure check valve. Available in a range of sizes to cover virtually all LP-Gas storage containers, these valves are UL listed and meet NFPA 58 2004 edition standards, as well as other safety requirements. Flow of liquid into the storage container opens both check valves. When flow stops, they both are designed to close automatically to permit the operator to disconnect the hose coupling. The automatic closing action also helps prevent the discharge of container contents in the event of hose failure. The lower back pressure check affords extra protection by restricting the discharge if the upper check fails to function properly due to accidents or other causes. The double back check construction allows emergency inspection, repair, or replacement of the upper fill assembly without removing product from the container. When the upper filler valve body is removed, the lower back check valve provides a seal, permitting only some leakage, allowing a new upper filler valve body to be installed.

DOUBLE CHECK FILLER VALVES FOR FORKLIFT, AUTOGAS, RV TANKS

Designed to provide fast filling of forklift, Autogas, and recreational vehicle tanks.



7647H 7647L 7647SC

Part no.		Hose Connection	Tank Connection M. NPT	Wrench Flats	Effective Length (Approx.)	Propane Liquid Capacity at Various Differential Pressures (GPM)***				
Basic	W/ Lanyard & Cap					10 PSIG	20 PSIG	30 PSIG	40 PSIG	50 PSIG
7647H	—	1/2" F. NPT	3/4"	1 1/2"	2 7/16"	14	20	24	27	50
—	7647DC	1 3/4" ACME & F. POL		1 5/8"	2 9/16"					
—	7647SC*	1 3/4" ACME		1 3/4"	1 11/16"					

* Large 134" hex wrench flats. ** 30° angle on 1 1/4" ACME hose connection. *** Multiply flow rate by .94 to determine liquid butane capacity.

COMBINATION FILLER AND OPD VALVES, LOW EMISSION

This combined filler valve and overfill protection device is designed to provide fast filling and protection against overfilling of Vertical above ground small bulk type containers. The SF7647V Series offers good fill rates and an overfill prevention, device that will stop the flow of product into the container when the liquid level reaches 80–83% of its capacity. Features:

- Large flow area for fast filling.
- Resilient seated upper check.
- Stable Overfill Protection Device that is integral to the filler valve.
- Overfill Protection Device will stop the flow of liquid when the 80–83% level is reached.

Part no.	Propane Liquid Capacity at Various Differential Pressures (GPM)			ACME Connection	Tank Connection
	20 PSIG	30 PSIG	25 PSIG		
SF7647V11.0	19	24	50	1 3/4" Male	3/4" M. NPTF
SF7647V11.1					



LOW EMISSION FILLER VALVE WITH MANUAL SHUTOFF FEATURE

Designed for fast filling of larger DOT cylinders and ASME domestic containers; the 7501L and 7502L feature a manual shutoff in addition to upper and lower back checks.

Features

- Low emission 2 cc or less at disconnect.
- Meets NFPA 58 and UL requirements.
- Double back check provides added system protection.
- Checks are spring activated for quick precise closure when flow stops.
- Hose end valve cannot be removed from the 7501L or 7502L if the lever is in the open position.
- When manual shutoff valve is closed, an integral back check prevents liquid from being trapped between the shutoff and upper check.

Part no.	Container Connection	ACME Hose Connection	Propane Capacity at Various Differential Pressures (GPM)		
			15 PSIG	25 PSIG	50 PSIG
7501L	1 1/4" M.NPT	1 3/4" M.ACME	62	90	125
7502L					



Non-stock/special order items are not cancellable or returnable

Shop online at www.raymurray.com or call **800-628-5044**

Check, Filler and Vapor Equalizing Valves



DOUBLE CHECK FILLER VALVES FOR LARGE AUTOGAS AND ASME TANKS

Designed to provide fast filling of large Autogas and ASME domestic tanks. The 6579 Series incorporates a swing-away lower check which greatly reduces pressure drop across the valve. This lower pressure drop promotes faster filling rates and greater efficiency resulting in more profitable operations.

Part no.		ACME Hose Connection	Tank Connection M. NPT	Wrench Hex Flats	Propane Liquid Capacity at Various Differential Pressures (GPM)				
With Cap Only	With Cap, Chain & Ring				5 PSIG	10 PSIG	25 PSIG	50 PSIG	75 PSIG
L7579***	L7579C***	1 3/4"	1 1/4"	1 7/8"	50	70	111	157	192
7579P	—		1 1/4**		37	52	82	116	142
L6579**	L6579C**		1 1/4"		78	110	174	246	301

* Incorporates 34" F. NPT dip pipe connection. ** Swing-away lower back check valve design for higher filling rate. ***L7579 & L7579C are Low Emission - only 2.14cc emissions. Replaces 7579 & 7579C, respectively. Note: Multiply flow rate by .94 to determine liquid butane capacity. Note: 7579C includes 3174-93L. 6579C includes 3174-93.

Spare Gasket Ordering Information

ACME	Part no.
1 1/4"	A2797-20R
1 3/4"	A2697-20R
2 1/4"	A3184-8R
3 1/4"	A3194-8R



COMBINATION LOW EMISSION FILLER AND OVERFILL PROTECTION DEVICE (OPD)

The SFL7579V Series filler valve is for use on ASME containers. This combined filler valve and overfill protection device is designed to provide fast filling and protection against overfilling of vertical and horizontal above ground LPG containers. This is typically installed in the top of horizontal containers. Low emission filler valve - will not release more than 2.14cc when disconnected. Stable Overfill Protection Device is integral to the filler valve, and will stop the flow of liquid when the 80% level is reached. **Note:** Must be installed in a vertical position. Depending on the application this valve is designed to be used in conjunction with another device such as a fixed liquid level gauge or float gauge in low emission transfer systems.

Part no.	ACME Hose Connection	Tank Connection M.NPTF	Wrench Hex Flats	Propane Liquid Capacity at Various Differential Pressures (GPM)			
				1 PSI	25 PSI	50 PSI	75 PSI
SFL7579V10.6	1 3/4" Male	1 1/4"	1 7/8"	23	49	54	66
SFL7579V11.1							
SFL7579V12.3							
SFL7579V13.0							
SFL7579V13.8							

* Suffix number indicates dip tube length (fixed liquid level gauge). Different lengths available upon request.



DOUBLE CHECK FILLER VALVES FOR DELIVERY TRUCK TANKS AND LARGE STORAGE CONTAINERS

Designed to provide fast filling of bobtails, transports and large bulk storage tanks. The 6587CD incorporates a swing-away lower check which greatly reduces pressure drop across the valve. This lower pressure drop promotes faster filling rates and greater efficiency resulting in more profitable operations.

Part no.	ACME Hose Connection	Tank Connection M. NPT	Wrench Hex Flats	Propane Liquid Capacity at Various Differential Pressures (GPM)				
				5 PSIG	10 PSIG	25 PSIG	50 PSIG	75 PSIG
7579S	1 3/4"	1 1/2"	2"	44	62	98	139	170
6587EC*	2 1/4"	2"	2 7/8"	92	130	206	291	356
3197C	3 1/4"	3"	4"	148	210	332	470	575

* Swing-away lower back check valve design for higher filling rates. NOTE: Multiply flow rate by .94 to determine liquid butane capacity.



Check, Filler and Vapor Equalizing Valves

SINGLE CHECK FILLER VALVES FOR STORAGE TANKS WITH SUPPLEMENTARY BACK CHECK VALVES

Designed for use with RegO® Back Check Valves to provide fast filling of bulk storage tanks. Also may be used as a spare or replacement part. *These single check filler valves must never be installed directly into container couplings. They must be used with the appropriate back check valve to comply with NFPA Pamphlet #58.*

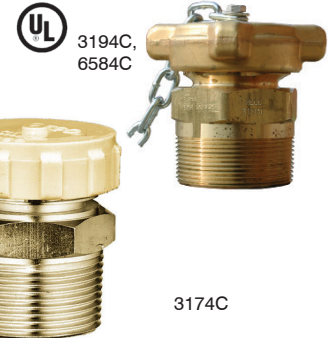

Part no.	ACME Hose Connection	Outlet Connection M. NPT	Wrench Hex Flats	Propane Liquid Capacity at Various Differential Pressures (GPM)				For use with Back Check Valve:
				5 PSIG	10 PSIG	25 PSIG	50 PSIG	
3174C	1 1/4"	1 1/4"	1 11/16"	23	33	52	74	3176
6584C*	2 1/4"	2"	2 3/8"	156	220	348	492	A3186
3194C	3 1/4"	3"	3 1/2"	147	208	329	465	A3196

* Stem Assembly designed for higher filling rates. NOTE: Multiply flow rate by .94 to determine liquid butane capacity.

VAPOR EQUALIZING VALVES - GENERAL INFORMATION

RegO® Vapor Equalizing Valves consist of an upper back check valve and lower excess flow valve. In the closed position, the attachment of a vapor hose coupling with its projecting nozzle, opens the back check valve to permit flow in either direction. The lower excess flow valve is designed to close automatically when flow out of the container being filled exceeds the rated capacity. The valve closes automatically when the coupling is removed. Like the double-check filler valves, the vapor equalizing valves utilize a two-piece body construction. The lower excess flow valve will permit some leakage when the upper back check valve is removed for emergency repairs or replacement. RegO® Vapor Equalizing Valves are designed for use in both ASME and DOT containers.

SPARE GASKET ORDERING INFORMATION

Part no.	Use	Size	Qty. in Package
A2797-20R	Filter, Vapor Valve and Adapter Connections	1 1/4" ACME	25
A2697-20R		1 3/4" ACME	25

For actual-size gasket pictures, see page A59.

DOUBLE CHECK VAPOR EQUALIZING VALVES FOR ASME AND DOT CONTAINERS

Designed to facilitate loading operations by providing equalization of pressures in the supply and storage containers. The supplementary excess flow valve closes when the flow from the container being filled exceeds a predetermined rate. The 7573 Series is designed for use in bulk delivery systems and Autogas containers. The 3183AC is designed for use in delivery trucks and other large containers.

Part no.		ACME Hose Connection	Tank Connection M. NPT	Wrench Hex Flats	Approximate Closing Flow at 100 PSIG Inlet Pressure (SCFH/Propane Vapor)
Basic	With Cap & Chain				
7573D	7573DC	1 1/4"	3/4"	1 3/8"	4,100
—	3183AC	1 3/4"	1 1/4"	2"	10,000

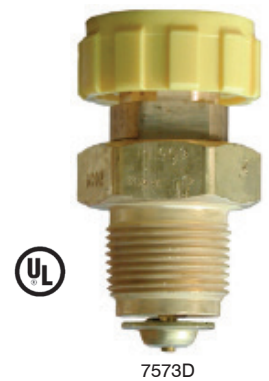
Vapor Equalizing Adapter for 1 1/4" ACME Vapor Equalizing Valves

Designed for use with RegO Multivalves® that utilize a vapor equalizing port and 7573 series vapor equalizing valves. The adapter's operating handle opens and closes the upper check stem in the vapor equalizing valve after the ACME connection is completely made up. Designed to eliminate the need for gas flow from the vapor equalizing valve whenever the adapter is installed or removed. *A shutoff valve, such as a full port ball valve or globe valve must be installed before the 7573-20 adapter to stop gas flow when the adapter is not connected.*

Adapter Number	Inlet Connection	Outlet Connection	Approximate Length	Approximate Width
7573-20	1 1/4" F. ACME	3/4" M. NPT	4 7/16"	2 3/8"



Non-stock/special order items are not cancellable or returnable

Shop online at www.raymurray.com or call **800-628-5044**

Check, Filler and Vapor Equalizing Valves



SINGLE CHECK VAPOR EQUALIZING VALVES FOR ASME & DOT CONTAINERS W/SUPPLEMENTARY EXCESS FLOW

Designed for use with RegO® Excess Flow Valves to facilitate loading operations by providing equalization of pressures in the supply and storage containers. Also may be used as a spare or replacement part. These vapor equalizing valves must never be installed directly into container couplings. They must be used with the appropriate excess flow valve to comply with NFPA Pamphlet #58.

Part no.		ACME Hose Connection	Tank Connection M. NPT	Wrench Hex Flats	Approximate Closing Flow at 100 PSIG Inlet Pressure (SCFH/Propane Vapor)	For Use with Excess Flow Valve
Basic	With Cap & Chain					
3170	—	1 1/4"	3/4"	1 1/4"	7,600	3272E
—	3180C	1 1/4"	1 1/4"	1 11/16"	10,000	3282A

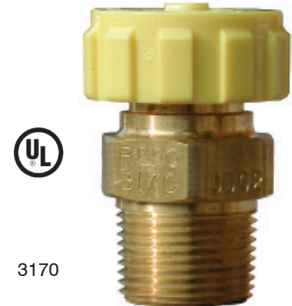

LOW EMISSION ACME CONNECTORS FOR TRANSPORTS AND BOBTAILS

Low Emission Connectors 6588LE & 6589LE

Features: 3 1/4" Male ACME Connector with **Reduced Emissions - 90% Less** than current RegO ACME Adapters. UL Listed as a Filler Valve. Safety groove is designed to shear below ACME threads, leaving the valve seat closed and unaffected if the vehicle pulls away with the hose connected. Seat disc is made of synthetic composition and is mechanically held in place by a seat disc retainer. Stainless Steel return spring. One-piece poppet stem for smooth operation. Will connect to any standard female 3 1/4" ACME adapter. Hydrostatic relief valve included (3125L).

Part no.	ACME Connection	Outlet Connection M. NPT	Wrench Flats	Hydrostatic Relief Valve	Propane Capacity at Various Differential Pressures (GPM)		
					5 PSIG	10 PSIG	25 PSIG
6588LE	3 1/4"	2"	3 1/2"	3125L	138	223	349
6589LE		3"					

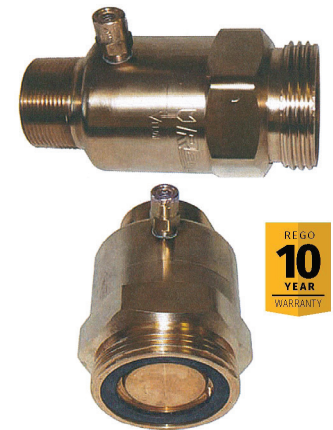

BACK PRESSURE CHECK VALVES - GENERAL INFORMATION

RegO Back Pressure Check Valves are designed to allow flow in one direction only. The check, normally held in the closed position by a spring, precludes the possibility of flow out of the container. When flow starts into the container, the pressure overcomes the force of the spring to open the check. When the flow stops or reverses, the check closes. Metal-to-metal seats will allow slight leakage after closure. These valves will restrict the escape of container contents in the event of accidental breakage of the piping or fittings.

BACK PRESSURE VALVES FOR CONTAINER OR LINE APPLICATIONS

Designed to provide protection of a container opening when desired flow is always into the vessel. May be used in line applications where flow must be limited to one direction. When used with the appropriate single check filler valve, the combination forms a double check filler valve suitable for use in filling of bulk storage tanks.

Part no.		A Inlet Connection F. NPT	B Outlet Connection M. NPT	C Wrench Hex Flats	D Effective Length (Approx.)	Propane Liquid Capacity at Various Differential Pressures (GPM)			
Brass	Steel					5 PSIG	10 PSIG	25 PSIG	50 PSIG
3146	A3146	3/4"	3/4"	1 3/8"	1 15/16"	11	16	25	36
3146S*	—								
3176	A3176	1 1/4"	1 1/4"	2"	1 13/32"	28	40	63	89
—	A3276BC*				2 1/8"	32	45	73	103
—	A3186	2"	2"	2 7/8"	2 3/8"	124	175	276	391
—	A3196	3"	3"	4"	3 7/32"	297	420	664	939
—	A3198S*	3" Male & 2" Female**	3" Male & 2" Female**	3 1/2"	3 1/4"	210	290	400	

*Soft seat version. ** Note: The 3" M. NPT connections on A3198S must be used for in-line service; the 2" outlet connection is for a standpipe when installed inside of a container.
NOTE: Multiply flow rate by .94 to determine liquid butane capacity and by .90 to determine liquid anhydrous ammonia capacity.



Check, Filler and Vapor Equalizing Valves



SWING AWAY BACK PRESSURE CHECK VALVES FOR CONTAINER OR LINE APPLICATIONS

Designed to provide protection of a container opening when desired flow is always into the vessel. May also be used in the line applications where flow must be limited to one direction. When used with the appropriate single check filler valve, the combination forms a double check filler valve suitable for use in filling of bulk storage tanks. The swing-away check offers more efficient flow rates than conventional designs. It swivels open vertically to reduce pressure drop across the valve and improves flow rates.

Part no.		Inlet Connection F. NPT	Outlet Connection M. NPT	Wrench Hex Flats	Propane Liquid Capacity at Various Differential Pressures (GPM)			
Brass	Steel				5 PSIG	10 PSIG	25 PSIG	50 PSIG
6586D		2"	2"	2 3/4"	190	270	420	600
	A6586D			2 7/8"				



6586D



NOTE: Multiply flow rate by .94 to determine liquid butane capacity.

BACK PRESSURE CHECK VALVES FOR FLANGED INSTALLATION

Designed to provide high flow capacity and allow more efficient tank filling than conventional designs. Unobstructed throat area reduces flow turbulence through valve, reducing pressure drop. Large flow channels and spacious side ports assure ample capacity for the most demanding high capacity filling operations. Designed for installation in internally threaded flanges in container bottoms.

Part no.	Flange Connection M. NPT	Wrench Hex Flats	Overall Length	Propane Liquid Capacity at Various Differential Pressures (GPM)			
				5 PSIG	10 PSIG	25 PSIG	50 PSIG
A3400L4	2"	Slotted	5 1/4"	223	316	500	707
A3400L6	3"		5 9/32"	424	600	949	1342



A3400L6



NOTE: For installation in flange tank connections with internal threads, see the "Flanged Installation in Container" section under "Excess Flow Valves." Multiply flow rate by .94 to determine liquid butane capacity and by .90 for liquid anhydrous ammonia capacity.

1 1/4" THREADED INTERNAL VALVES

A3209D & A 3209DT Series for Small Capacity Pumping Systems and Bobtail Vapor Equalization

Designed primarily for use with LP-Gas and anhydrous ammonia as a main valve on small capacity pumping systems, NH3 nurse tanks and in-line installations. It may also be installed in the vapor equalizing opening on bobtail delivery trucks. Installation is quick and easy, and it fits in both full and half couplings, as well as, in-line applications. The valve may be actuated manually by hand or cable. **Note:** A3209D replaces A3209R.



A3209TL

A3209PAF

A3209PA

Part no.	Inlet Connection M. NPT	Outlet Connection F. NPT	Closing Flow** (GPM)		LP-Gas Vapor Capacity** (SCFH/Propane)		Accessories		
			LP-Gas	NH ₃	25 PSIG Inlet	100 PSIG Inlet	Thermal Latch	Pneumatic Actuators	Rotary Actuator
A3209D050	1 1/4"	1 1/4"	50	45	13,300	22,900	A3209TL	A3209PAF	A3209OA
A3209D080			80	72	15,700	26,700			
A3209DT050	1 1/4"	1 1/4"	50	45	13,300	22,900			
A3209DT080			80	72	15,700	26,700			

*Installs in full or half coupling. **Data for flow in half coupling.

 A3209D
Series

1 1/2" STRAIGHT THROUGH INTERNAL VALVE

Designed primarily for use with LP-Gas and anhydrous ammonia as a main valve on pumping systems and in-line installations. Installation is quick and easy. Fits in both full and half couplings, as well as in-line applications. Valve may be opened manually by hand or pneumatic actuator.

Part no.	Inlet M. NPT	Outlet F. NPT	Closing Flow GPM				LP-Gas Vapor Capacity (SCFH/Propane)		Accessories		
			Half Coupling		Full Coupling		25 PSIG Inlet	100 PSIG Outlet	Thermal Latch	Pneumatic Actuator	Rotary Actuator
			LP-Gas	NH ₃	LP-Gas	NH ₃					
A3211D080	1 1/2"	1 1/2"	80	72	63	67	15,700	26,700	A3209TL	A3209PAF	A3209OA
A3211D110			110	99	84	76	N/A	N/A			



A3211D

Non-stock/special order items are not cancellable or returnable

Shop online at www.raymurray.com or call **800-628-5044**

Internal Valves & Accessories



3" FLANGED INTERNAL VALVE FOR BOBTAILS, TRANSPORTS, & LARGE STATIONARY STORAGE TANKS

Designed primarily for LP-Gas and anhydrous ammonia filling and/or withdrawal on MC331 bobtail delivery trucks, transports and stationary storage tanks with flanged pumps or piping. Installation is quick and easy, and the valve may be operated manually by cable or pneumatically. Lever available on right or left side to allow for installation without the use of an extra pulley.

Part no.		Operating Lever Position	Inlet Connection	Outlet Connection	Closing Flow GPM		Accessories
Single Flange Body	Double Flange Body				LP-Gas	NH ₃	
A3217AR160	A3217DAR160	Right Side	3" 300# ANSI RF Modified Flange**	3" 300# ANSI RF Flange	160	145	A3217ARPA
A3217AL160	A3217DAL160	Left Side					A3217ALPA
A3217AR210	A3217DAR210	Right Side			210	190	A3217ARPA
A3217AL210	A3217DAL210	Left Side					A3217ALPA
A3217AR260	A3217DAR260	Right Side			260	236	A3217ARPA
A3217AL260	A3217DAL260	Left Side					A3217ALPA
A3217AR410	A3217DAR410	Right Side			410	372	A3217ARPA
A3217AL410	A3217DAL410	Left Side					A3217ALPA
A3217AR510	A3217DAR510	Right Side			510	459	A3217ARPA
A3217AL510	A3217DAL510	Left Side					A3217ALPA



* Valve supplied with 16 nuts and 8 studs for mounting. ** Modified bore = 4 5/8" diameter with 5 3/4" diameter raised face.

4" FLANGED INTERNAL VALVE FOR TRANSPORTS AND LARGE STATIONARY STORAGE TANKS

Designed primarily for LP-Gas and NH₃ service on MC331 transport pressure vessels and large stationary storage tanks. Installation is quick and easy, and it fits in most existing tank flanges. Valve may be actuated manually or pneumatically. Use of the A3219RT Remote Thermal Release with this valve is suggested to provide a remote means of mechanical closure along with thermal protection, as required by DOT.

Part no.*	Inlet Connection	Outlet Connection	Closing Flow (GPM)		Accessories			
			LP-Gas	NH ₃	Pneumatic Actuator	Remote Thermal Release	Rotary Actuator	
A3219FA400L	4" 300# ANSI RF Modified Flange**	4" 300# ANSI RF Flange	400	360	A3219FPA	A3219RT	(2)	A3219RA
A3219FA600L			600	540	A3219RA			A3219FRA
A3219FA600W			---	A3219W	---			

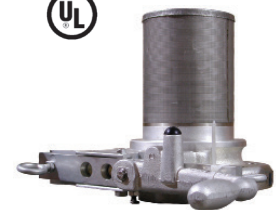

* Valve supplied with 16 nuts and 8 studs for mounting. ** Modified bore = 5 7/8" diameter with 7" diameter raised face.

REMOTE THERMAL RELEASE FOR DOT MC331 PRESSURE VESSEL

Designed especially for use with Internal Valves installed in DOT MC331 pressure vessels. The A3219RT provides a remote means of mechanical closure along with thermal protection, as required by DOT MC331. The A3219RT is connected by cable to the internal valve(s) on the vessel. In the event of extreme heat (over 212° F.), the fuse link will melt, causing the spring to contract and pull the cable. When properly installed the cable will trip the internal valve release lever(s) allowing the connected handle(s) to move to the closed position.

Part no.	For Use With	Release Temperature	Spring Load		Minimum Number Required by MC331
			Fully Extended	After 4" Travel	
A3219RT	Internal Valves	212° F	100 lbs.	50 lbs.	2

A3219RT



REMOTE CABLE CONTROLS FOR INTERNAL VALVES

The 3200C Remote Cable Kit is designed especially for use with the 3200L Remote Operating Lever to operate internal valves from a remote location. The internal valve is opened by pulling back the remote operation lever and closed by returning the lever to its original position. A remote release is provided to close the internal valve from a different remote location.

Part no.	Description	Contents
3200C	Remote Cable Kit	100 Foot Cable, 6 Cable Clamps, Quick Link, Sign, Fuse Link, Steel Nut and Bolt.
3200L	Operating Lever	Lever Assembly

3200L



Non-stock/special order items are not cancellable or returnable

Shop online at www.raymurray.com or call **800-628-5044**

Internal Valves & Accessories

FLOMATIC® INTERNAL VALVES - GENERAL INFORMATION

RegO® piston type Flomatic® Internal Valves are normally closed and use pressure differential to provide completely automatic service. Mounted directly between the tank body and pump, the Flomatic® uses the pressure differential developed by the pump to open the valve and it closes automatically when the differential no longer exists. This means the RegO® Flomatic® opens when the pump is on and closes when the pump is shut off - fully automatic.

FLOMATIC® INTERNAL VALVES FOR BOBTAILS, TRANSPORTS & LARGE STATIONARY STORAGE TANKS

Designed primarily for LP-Gas and anhydrous ammonia liquid withdrawal on MC331 bobtail delivery trucks, transports and large stationary storage containers with flanged connections. The valve is fully automatic, opening and closing as the pump is turned on or off.



Part no.	Inlet Connection ANSI Flange	Outlet Connection ANSI Flange	Strainer Width	Base Width	Overall Height (Approx.)	Height From Indicator to Base	Accessories (Included w/ Flomatic)	
							Filter	3-Way Valve
A7883FK	3" 300#**	3" 300#	4¾"	8¼"	10 7/8"	4 13/16"	A7884-201	A7853A
A7884FK	4" 300#***	4" 300	5¾"	10"	11¼"	4 15/16"	Pneumatic Actuators	
							A7853PA	A7853PAF

*Supplied with A7853A 3-way valve, A7884-201 filter, studs, nuts and gaskets. **With 4 13/16" diameter bore. ***With 5 13/16" diameter bore.

THREADED INTERNAL VALVES FOR BOBTAILS, TRANSPORTS & STATIONARY STORAGE TANKS

Designed primarily for use with LP-Gas and Anhydrous Ammonia for liquid or vapor transfer; vapor equalization of bobtail delivery trucks, transports, stationary storage tanks, and in-line installations. The valves may be operated horizontally or vertically and manually by cable or pneumatically.

A3212R and A3213D Series

Part no.	Inlet Connection M. NPT	Outlet Connection F. NPT	Closing Flow (GPM) Half Coupling		Closing Flow (GPM) Full Coupling		Accessories		
			LP-Gas	NH ₃	LP-Gas	NH ₃	Rotary Actuator	Thermal Latch	Pneumatic Actuator
A3212R105	2"	2"	105	95	65	59	A3212RA	A3213TL	A3213PA
A3212R175			175	158	100	90			
A3212R250			250	225	130	117			
A3213D150	3"	3"	150	135	125	113	A3213RA	A3213TL	A3213PA
A3213D200			200	180	160	144			
A3213D300			300	270	250	225			
A3213D400			400	360	325	293			

A3212RT Series and A3213DT Series

Part no.	Inlet Connection M. NPT	Outlet Connection F. NPT	Closing Flow (GPM) Half Coupling		Closing Flow (GPM) Full Coupling		Accessories		
			LP-Gas	NH ₃	LP-Gas	NH ₃	Rotary Actuator	Thermal Latch	Pneumatic Actuator
A3212RT105	2"	2"	105	95	65	59	A3212RA	A3213TL	A3213PA
A3212RT175			175	158	100	90			
A3212RT250			250	225	130	117			
A3213DT150	3"	3"	150	135	125	113	A3213RA	A3213TL	A3213PA
A3213DT200			200	180	160	144			
A3213DT300			300	270	250	225			
A3213DT400			400	360	325	293			



NOTE: The A3212PA pneumatic actuator and A3212TL thermal latch will not work with A3212R or A3212RT Series threaded internal valves.



Adapters, Connectors & Fittings



EXTENDED TYPE HOSE COUPLINGS FOR VAPOR AND LIQUID SERVICE

Designed especially for liquid filling and vapor equalization of LP-Gas and anhydrous ammonia. The limited travel of the handle on the tailpiece minimizes spin-off, encouraging cautious removal to properly bleed off trapped product to assure closure of the filler valve and hose end valve. The ACME threads are machined on a rugged steel insert which is permanently cast in the aluminum handle, providing for durability under repeated use.

Part no.	Type of Service	Hose Connection M. NPT	Coupling Connection F. ACME	Approximate Length
A7575L2*	Liquid	1/2"	1 3/4"	7"
A7575L3		3/4"		
A7575L4		1"		
A7575L5**		1 1/4"		
A7571LA	Vapor	1/2"	1 1/4"	
A7571LB		3/4"		

* Includes 7199-33 adapter, shipped loose.
 ** Includes A7575L5-1 adapter, shipped loose.



A7571 Series



A7575 Series

SHORT TYPE HOSE COUPLINGS FOR VAPOR AND LIQUID SERVICE



Style A for liquid filling. 3175 Series



Style B for liquid filling. A3185



Style C for vapor equalizing. 3171 Series



Style D for vapor equalizing. 3191 Series



Part no.	Material	Style	Hose Connection (M. NPT)	Coupling Connection (F. ACME)	Tailpiece Bore	Hose End to Nut	Overall Length	
3175B	Brass	A	1/2"	1 3/4"	35/64"	2"	2 7/8"	
3175			3/4"		3/4"			
3175A			1"		3/4"			
3185	Brass Nut & Steel Nipple	B	1 1/4"	2 1/4"	1 3/16"	2 1/16"	3 1/8"	
3195			2"	3 1/4"	1 13/16"	2 1/4"	3 5/8"	
3195S								
A3195S	Steel	A	3/4"	1 3/4"	7/8"	2"	2 7/8"	
A3175			1"					
A3175A								
A3185	Brass	B	1 1/4"	2 1/4"	1 3/16"	2 1/8"	3 1/8"	
A3195			2"	3 1/4"	1 7/8"	2 1/4"	3 5/8"	
3171			C	3/8"	1 1/4"	3/8"	1 3/16"	2 13/32"
3171A	1/2"	31/64"						
3181	3/4"	3/4"		1 3/16"		2 11/16"		
3181A	1"	3/4"		1 7/8"		2 3/4"		
3191	1 1/4"	2 1/4"		1 3/16"		2 1/8"		



Non-stock/special order items are not cancellable or returnable

Shop online at www.raymurray.com or call 800-628-5044

Adapters, Connectors & Fittings

ACME CHECK CONNECTORS FOR LIFT TRUCKS

Brass connectors especially designed to join the carburetor fuel line to the service valve on lift truck cylinders. Sturdy, long lasting ACME threads allow quick, hand-tight assembly that provides for quick and simple cylinder replacement. Back checks automatically close in each connector when disconnected. The 7141M couples directly to the service valve. An integral O-ring is designed to seal before the internal check opens, aiding in product loss prevention. A gasket at the ACME thread is a secondary seal when the connectors are tightened together. The connector fits RegO® lift truck cylinder filling adapters for fast, convenient filling. The 7141F accepts fuel line adapter and couples directly to the 7141M. The O-ring seal in the 7141M is designed to seal before the internal check opens to allow product to pass through the connection. The knurled coupling eases threading and the ACME threads provide rapid effortless make-up, even against LP-Gas pressure.

Part no.	Application	Inlet	Outlet	Protective Cap*		Replacement Gaskets Pack of 25
				Rubber	Brass	
7141M	Service Valve	3/8" F. NPT	1/4" M. ACME	7141M-40	7141FP	7141M-3R
7141F	Fuel Line	1/4" F. ACME	1/4" F. NPT	—	—	—

* Recommended to minimize foreign material entering valves which could result in leakage.

7142LF AND 7142LM LEFT HAND THREAD ACME CONNECTORS
For Vapor Withdrawal Industrial Cylinders Designed for Propane Fueled Lawn Mowers

Brass connectors designed to join the carburetor vapor fuel line to the service valve on industrial cylinders, especially designed for and used on propane fueled lawn mowers. Sturdy long lasting ACME left hand threads provide for quick hand tight assembly that enables quick and simple cylinder replacement.

Part no.	Application	Inlet	Outlet	Protective Cap
				Rubber
7142LM	Vapor Service Valve	3/8" F. NPT	1/4" M. ACME - <i>left hand</i>	7141M-40
7142LF	Vapor Fuel Line	1/4" F. ACME - <i>left hand</i>	1/4" F. NPT	—

UNLOADING ADAPTERS FOR CONTAINER EVACUATION

Designed to provide an efficient means of evacuating an LP-Gas container for relocation or repair. They thread directly onto the 1" ACME male hose connection of RegO® Filler Valves used on RegO® Double Check Filler Valves and Multivalves®. The unloading adapters can be used to withdraw liquid provided the container is equipped with a dip pipe extending from the filler valve to the bottom of the container.

Part no.	Style	Filler Valve Connection	Hose Connection
3119A	In-Line	1 3/4" F. ACME	1 3/4" M. ACME
3120	Angle		3/4" F. NPT
3121			

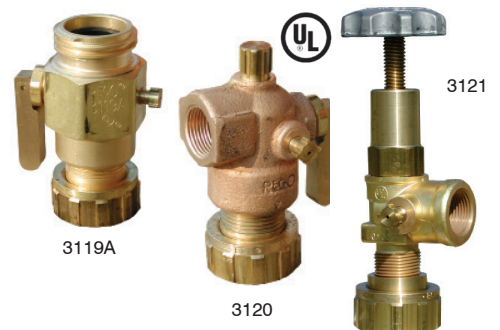
FILLER HOSE ADAPTERS

These adapters are designed with minimal flow restriction and recommended for use on the outlet of the LP-Gas delivery truck filler hose. If the controlled bleed off of the connection indicates the filler valve on the tank being filled has failed to close, the hose adapter should be left in place on the filler valve and disconnection should be made at the regular filler hose coupling. (Repair of the filler valve must be made as soon as possible). An integral check valve in these adapters helps prevent further loss of product. The standard filler valve cap should be attached to these adapters when left on the container.

Part no.	Built-In Vent Valve	Filler Valve Connection	Hose Connection
7577V	Yes	1 3/4" F. ACME	1 3/4" M. ACME
3179A	No		
3179B			

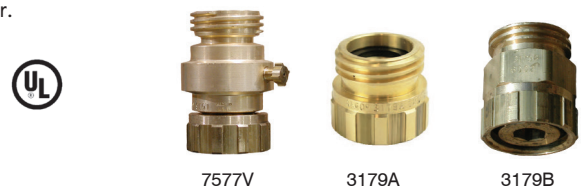

Adapters, Connectors & Fittings



ACME PLUGS

Specifically designed to withstand the everyday abuse given hose end valves on delivery trucks and hose end couplings on risers in bulk plants. These rugged plugs protect the coupling tip as well as prevent the entrance of dirt, dust, snow and rain. They also prevent possible gas contamination from these same sources. The heavily ribbed outer surface permits hand-tight make-up.

Part no.	Material	M. ACME	Chain & Ring Fits Pipe Size Up to:
C5763N	Nylon	1 1/4"	3/4"
C5765N		1 3/4"	1 1/4"
5765PR	Brass		Not Applicable
C5767N	Nylon	2 1/4"	1 1/4"
C5769N		3 1/4"	2"



POL PLUGS

Highly recommended for installation in LP-Gas cylinder valve POL outlets whenever the service line is disconnected or when the cylinder is being transported. When properly installed, the POL plug is designed to prevent contamination of the valve outlet and guards against product leakage if the cylinder valve is accidentally opened.

Part no.	Material	Connection
N970P	Cyclac	M. POL (CGA 510)
10538P*	Brass	
3705RC		



* 10538P Has hole for attaching wire to prevent loss of plug.

CAPS AND REDUCER COUPLINGS

Cap with Chain & Ring		Cap/Reducer Only Part no.	Material	Thread Connection		
Part no.	Ring Fits Pipe Size Up To:					
3144-91	3/4"	3144-9P	Cyclac	1 1/4" F. ACME		
3174-91		3174-9P				
3174-93		1 1/4"			A8016-9P	Nylon
A8016-93						
1708C	3/4"	—	Brass	F. POL (CGA 510)		
7141FP	1 1/4"			1 1/4" F. ACME		
3175P				1 3/4" F. ACME		
A3175P	1 1/4"		Steel	1 3/4" ACME		
3184-90	2"	5774*	Brass	2 1/4" F. ACME		
3194-90				3"	3194-9	3 1/4" F. ACME
—					5776*	
A3184-90	2"	—	Steel	2 1/4" F. ACME		
A3194-90	3"			3 1/4" F. ACME		
—	—			A5776*		

* Reduces to 1 3/4" M. ACME



5774



5776

3144-91 Plastic Cap

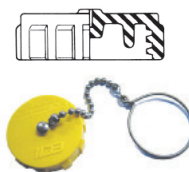

7141FP Cap Plug

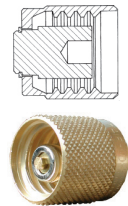

3194-90 Metal Cap

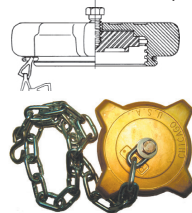

1708C POL Cap



A5776 Reducer Coupling

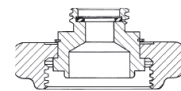

3175P Cap Plug

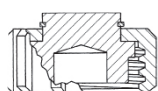

Adapters, Connectors & Fittings

ACME ADAPTERS
ACME x Female NPT

Part no.	Material	A M. ACME	B F. NPT	C Hex	D Overall Length	E Diameter	Spare Gasket Part No.		
5764A	Brass	1 3/4"	1/4"	1 3/4"	1 3/4"	13/32"	A2697-20R		
5764B			3/8"		1 23/32"	9/16"			
5764C			1/2"		1 1/4"	11/16"			
5764D			3/4"		1 9/32"	29/32"			
5764E			1"		1 5/16"				
5766E			2 1/4"		1"	2 1/4"		1 3/32"	A3184-8R
5766F					1 1/4"			1 3/8"	
5768G	3 1/4"	1 1/2"	3 1/4"	1 3/4"	1 11/16"	A3194-8R			
A5764D	Steel	1 3/4"	3/4"	1 3/4"	2 3/16"	7/8"	A2697-20R		
A5764E			1"						
A5768H			3 1/4"					2"	3 1/4"

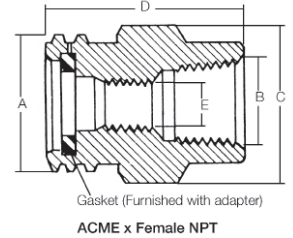

5764A

ACME x Male NPT

Part no.	Material	A M. ACME	B M. NPT	C Hex	D Overall Length	E Diameter	Spare Gasket Part No.		
5763D	Brass	1 1/4"	3/4"	1 1/4"	1 3/4"	1/2"	A2797-20R		
5765D			3/4"		1 3/4"	1 23/32"	29/32"	A2697-20R	
5765E			1"			2 3/32"			
5765F			1 1/4"						
5767F			2 1/4"		1 1/4"	2 1/4"	2 3/8"	1 3/16"	A3184-8R
5767G					1 1/2"			1 3/8"	
5767H					2"			2 3/8"	
5769K	3 1/4"	3"	3 1/2"	3 5/8"	2 1/8"	A3194-8R			
A5765C	Steel	1 3/4"	1/2"	1 3/4"	2 3/16"	17/32"	A2697-20R		
A5765D			3/4"			11/16"			
A5765E			1"			57/64"			
A5765F			1 1/4"						
A5767F			2 1/4"			1 1/4"		2 3/8"	1 1/4"
A5769H	3 1/4"	2"	3 1/4"	2 7/8"	1 15/16"	A3194-8R			
A5769K		3"					4"	3 13/16"	

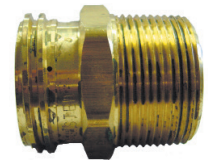
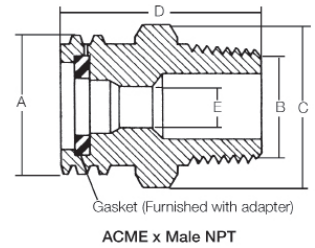
5778 ACME REDUCING ADAPTER

Part no.	Body Material	Description
5778	Brass	3 1/4" F-ACME x 2 1/4" M-ACME Reducing Adapter



Adapters, Connectors & Fittings



ACME ADAPTERS (CONTINUED)

ACME x ACME

Part no.	Material	A M. ACME	B Hex	C	D Diameter	Spare Gasket Part No.
5765M	Brass	1 3/4"	1 3/4"	2 1/16"	7/8"	A2697-20R
5767M		2 1/4"	2 1/4"	2 5/16"	1 25/64"	A3184-8R
5769M		3 1/4"	3 1/4"	2 3/4"	2 1/8"	A3194-8R

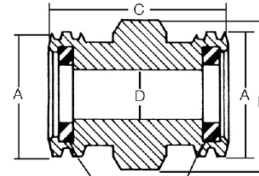

Gasket (Furnished with adapter)
ACME x ACME



ACME x Miscellaneous

Part no.	Material	A M. ACME	B Thread	C	D Hex	Spare Gasket Part No.
A5764W	Steel	1 3/4"	3/8"*	1 1/4"	1 3/4"	A2697-20R
5764W	Brass					

*3/8" -16 UNC Thread.

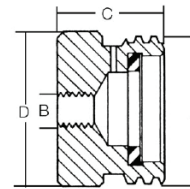

ACME x Miscellaneous
(Recommended for securing hose-end valve when not in use).



3 1/4" M. ACME x 2" M. NPT Adapter With Vent Valve and Integral Screen

Part no.	Vent Valve	Hex Size	Thread	"A" Length
5769H	-	3 1/4"	2" MNPT	2.875
5769HVB	3165CBT			3.15
5769HVSS	TSS3169			

5769HVB



MALE POL SWIVEL ADAPTERS

Part no.	Material	A	B Hex	C Drill	D	Closing Flow (Propane)	
						Vapor at 100 PSIG Inlet (SCFH)	Liquid (GPM)
970	Brass	1/4" M. NPT	7/8"	5/16"	2 3/8"	—	—
970S				3/16"	2 3/32"	—	—
970AX				5/16"	2 5/64"	404	1.1
970AXS					2 7/16"	450	0.95
3199W				1 3/8"	2 3/32"	—	—
970AW					3/16"	—	—
970HT		1/4" Hose Barb	1 7/8"	5/32"	2 5/8"	—	—
970JR				—	—	—	

Note: All nipples incorporate wrench hex section.

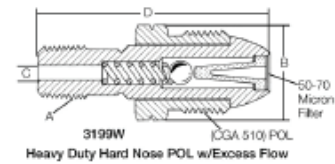

3199W (CGA 510) POL
Heavy Duty Hard Nose POL w/Excess Flow

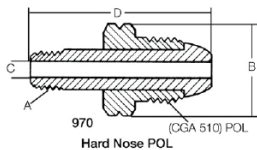

970 (CGA 510) POL
Hard Nose POL

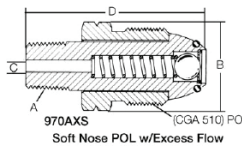
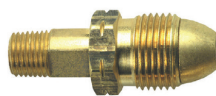

970AXS (CGA 510) POL
Soft Nose POL w/Excess Flow

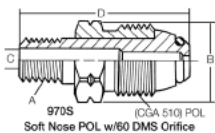
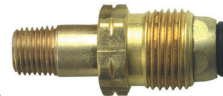

970S (CGA 510) POL
Soft Nose POL w/60 DMS Crifice

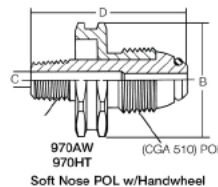

970AW (CGA 510) POL
970HT
Soft Nose POL w/Handwheel

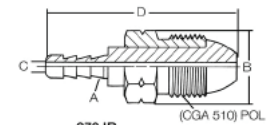

970JR (CGA 510) POL
Hard Nose POL w/Hose Barb Connection



Adapters, Connectors & Fittings

POL ADAPTERS
Male POL x Female NPT

Part no.	Material	A F. NPT	B	C Hex	D
2906A	Brass	1/4"	1 3/8"	1 5/16"	1/4"
2906G		1/2"	2"	1 1/8"	

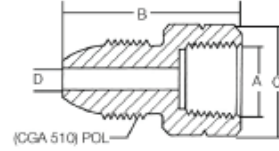

Male POL x Female NPT

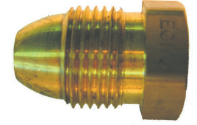
Male POL x Male NPT and SAE Flare

Part no.	Material	A	B	C Hex	D Diameter
2906D	Brass	3/8" M. NPT	2 1/16"	15/16"	11/32"
2906F		3/8" SAE Flare	2 3/32"	7/8"	
2906E		1/2" SAE Flare	2 1/4"		9/32"

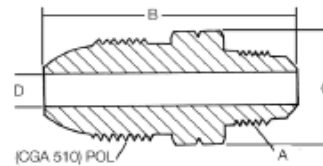

Male POL x Male NPT and SAE Flare

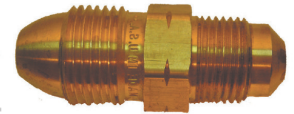
Female POL x Female NPT and Female POL

Part no.	Material	A F. NPT	B	C Hex	D Diameter
5760Z	Brass	1/8"	1 5/8"	1 1/8"	5/16"
5760A		1/4"			13/32"
5760B		3/8"			35/64"
5760C		1/2"			43/64"
5760D		3/4"	1 7/8"	1 3/8"	13/32"
5760S		POL (CGA510)	2 1/8"	1 1/8"	

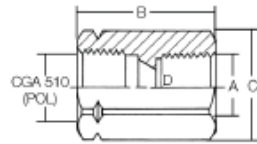

Female POL x Female NPT and Female POL



 5760S
POL x POL
Coupling / Union

Female POL x Male NPT

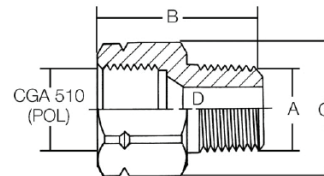
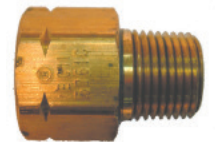
Part no.	Material	A M. NPT	B	C Hex	D Diameter
5761A	Brass	1/4"	1 5/8"	1 1/8"	3/16"
5761B		3/8"			13/32"
5761C		1/2"			7/16"
5761D		3/4"			

 CGA 510
(POL)

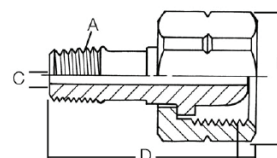
CGA 555 SWIVEL ADAPTERS

Part no.	Material	A	B Hex	C	D
12982	Brass	1/4" M. NPT	1 1/4"	3/16"	1 15/16"

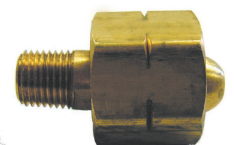

CGA 555



Non-stock/special order items are not cancellable or returnable

 Shop online at www.raymurray.com or call **800-628-5044**

Adapters, Connectors & Fittings



HOSE ADAPTER FOR USE WITH FUEL GASSES (LP-GAS, ACETYLENE)

Part no.	Material	A	B
1300	Brass	9/16" -18NF (L.H.)	1/4" M. NPT

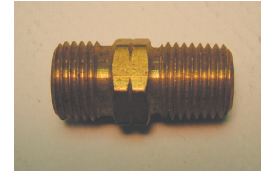
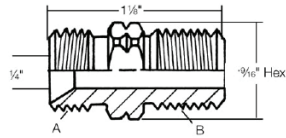

PRESSURE GAUGE ADAPTER

Part no.	Material	A	B	C
1494-1	Brass	1/2" F. NPT	1/4" F. NPT	1/2" M. NPT

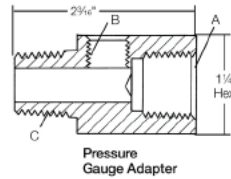

MISCELLANEOUS ADAPTERS

Male UNF x Female UNF x Hose Barb

Adapters	Description
1328	3/8" M. Flare x 3/8" F. Flare Swivel
1331	1/2" M. Flare x 1/2" F. Flare Swivel
1332	5/8" M. Flare x 5/8" F. Flare Swivel



ACME CAPS WITH LANYARD AND NAMEPLATE

3 1/4" Brass ACME Caps feature name plates calling out liquid, vapor or spray fill. In addition, this ACME cap assembly is fitted with a cable type lanyard crimped and installed on the cap.

Cap with Label/Lanyard

Part no.	Marked on Cap	Material	Thread Connection
3194-91L	Liquid	Brass	3 1/4" FACME
3194-91S	Spray Fill		
3194-91V	Vapor		
A3194-91L	Liquid	Steel	
A3194-91S	Spray Fill		
A3194-91V	Vapor		

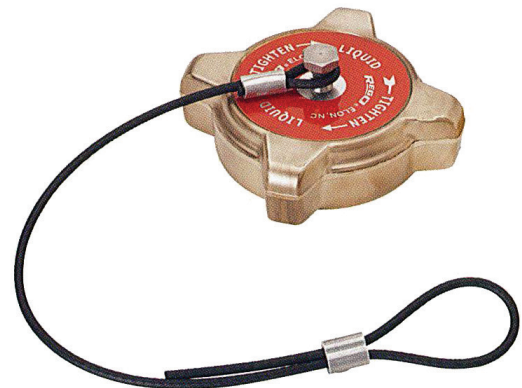

Name Plate Only

Part no.	Marked on Cap	Material
3194-11AL	Liquid	Aluminum
3194-11AS	Spray Fill	
3194-11AV	Vapor	
3194-11ALS	2-sided Liquid / Spray Fill	



3194-11AL Plate



3194-11AV Plate

Miscellaneous Equipment

1" ROTOGAGES® FOR LARGE MOBILE AND STATIONARY CONTAINERS

Rotogages® are designed to provide an accurate determination of LP-Gas or anhydrous ammonia container contents. They mount in a standard 1" NPT coupling on large mobile or stationary containers. To operate the Rotogages®, the vent valve is opened and the dip tube rotated slowly from the container vapor space to the liquid space. The difference in appearance of the discharge indicates when the liquid level is reached. Dial readings then indicate the percentage of product in the container.



A9091-18L

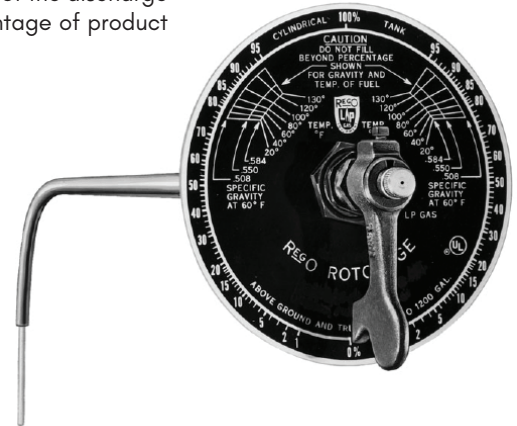

Rotogauge Assembly

Rotogage® Dials

Part no.	Service	Container Size
A9091-18L	LP-Gas	All Sizes
A9091-18LX*	LP-Gas	Over 1,200 US Gallons
A9091-18N	NH ₃	All Sizes

Rotogage® Ordering Information

Part no.				For Container Inside Diameter			
For Use with LP-Gas		For Use With NH ₃		Ellipsoidal Heads		Hemispherical Heads	
For Mobile or Stationary Containers	For Stationary Containers Only	For Mobile or Stationary Containers	For Stationary Containers Only				
				Side Mounted	End Mounted	Side Mounted	End Mounted
A9091R	—	A9091R	—	30"-45"	30"-75"	30"-45"	30"-45"
A9091-M24		A9091-M24					
A9092R	—	A9092R	—	46"-61"	76"-108"	46"-61"	46"-61"
A9091-M36		A9091-M36					
A9093TS	A9093RS	A9093TS	A9093RS	62"-79"	109"-147"	62"-79"	62"-79"
A9091-M48*	A9091-M48	A9091-M48*	A9091-M48				
A9094TS	A9094RS	A9094TS	A9094RS	80"-99"	—	80"-99"	80"-99"
A9091-M60*	A9091-M60	A9091-M60*	A9091-M60				
A9095TS	A9095RS	A9095TS	A9095RS	100"-147"	—	100"-147"	100"-147"
A9091-M72*	A9091-M72	A9091-M72*	A9091-M72				

* Supported Design. NOTE: The dip tube must be cut to the required length (1/2 of container inside diameter minus 5 3/4").



Miscellaneous Equipment



SIGHT FLOW INDICATORS FOR BULK PLANTS

Designed to promote maximum pump efficiency, these indicators enable bulk plant operators to visually inspect liquid flow conditions. With glass on both sides of the indicator, flow can be observed from either side, even under some poor light conditions. Integral swing check also serves as a back-check valve to prevent reverse flow and product loss if the hose fails in a loading operation.

By installing an indicator on the upstream side of the plant pump, suction conditions can be observed and the pump speed adjusted to obtain the maximum possible flow rate without cavitation. Additionally, if an indicator is installed in the piping at the loading rack, just ahead of the loading hose, the operator can maintain a constant check on pump conditions. Both installations are designed to allow for observation to provide maximum pump efficiency and assure safe plant pump operation.

In compressor operations a sight flow indicator installed in the liquid line will give a visual indication when the tank car or transport is emptied. Compressor operation can then be immediately reversed to start recovery of the vapor.

Part no.	Inlet / Outlet Connections	Length
A7794	2" F. NPT	5 3/4"
A7796	3" F. NPT	7 3/8"

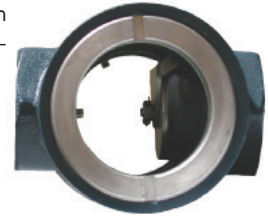

PULL AWAY VALVES FOR TRANSFER OPERATIONS

Designed especially to provide pull-away protection for LP-Gas and anhydrous ammonia transfer operations including transport and delivery truck loading and unloading, engine fuel container filling and miscellaneous cylinder filling operations. When properly fastened to the inlet end of the discharge hose, the valve is designed to stop gas escape from both upstream and downstream lines in the event of a pull-away. An excessive tension pull causes the valve to automatically separate, closing two internal back pressure checks. Only a few cubic centimeters of gas escape at the instant of separation.

It is recommended that a convenient means be provided to safely remove the pressure from the line upstream of each coupling half to enable reassembly of the valve. To reassemble, simply push the male half firmly into the female half until the retaining balls slip into the retaining groove. Check for leaks after reassembly.

NOTE: It is recommended that pull-away valves be safety-tested at least monthly to confirm that they will separate properly in the event of a pull-away. Dry nitrogen or other inert gas is suggested for a source of pressure during such tests.



A2141A10

Part no.	Inlet/Outlet Connections F. NPT	Disconnect Force Approx. lbs.	Reconnect Force Approx. lbs.	Length of Valve	LP-Gas Liquid Flow Capacity at Various Differential Pressures (GPM)*			
					5 PSIG	10 PSIG	25 PSIG	50 PSIG
A2141A6	3/4"	130	80	3 7/8"	11	16	25	36
A2141A6L								
A2141A8	1"	75	50	4 9/16"	21	30	47	67
A2141A8L								
A2141A10	1 1/4"	160	25	5 5/8"	52	75	120	170
A2141A16	2"	300	50	14 5/16"	250	350	550	750

* To determine NH3 liquid flow capacity, multiply by .90.

HEAVY DUTY SWING CHECK WITH FLOW INDICATOR

Designed to provide required back flow protection for the unloading riser in the bulk plant's transfer area. Designed specifically for pipeline installation and suitable for LP Gas and Anhydrous Ammonia service. Product flow moves the swing check to the open position. When flow stops, the spring loaded swing check closes.

Part no.	For Use With:	Inlet & Outlet Connections	Liquid Flow Capacity at 10 PSIG Drop (GPM)
A7616	LPG & NH3	2" F. NPT	711 GPM (LPG) / 640 GPM (NH3)
A7624		3" F.NPT	1325 GPM (LPG) / 1173 GPM (NH3)



A7616



Non-stock/special order items are not cancellable or returnable

Shop online at www.raymurray.com or call 800-628-5044

Miscellaneous Equipment

EMERGENCY SHUTOFF VALVES
A6010, A6016 & A6024 Emergency Shutoff Valves

Designed for installation in liquid or vapor transfer lines at LP-Gas or Anhydrous Ammonia bulk plants to provide for quick shut-off of liquid or vapor flow in the event of an accidental pull-away, line break, or hose rupture.

- Fusible element is located in the thermal fuse assembly, which acts as latch open and close trigger. When exposed to fire, the element melts at 212° F, allowing the shaft to return to the closed position.
- Valve can be opened by use of operating lever. If a pneumatic actuator is used, it will open with the actuator.
- Valve can be closed by remote cable or pneumatic actuator.
- Valve can be closed by simply pushing the operating lever down; it is not necessary to trip the close trigger.

Meets NFPA 58 and UL requirements.



Part no.	Seat	Inlet & Outlet Connections	Accessories			Liquid Flow @ 10 PSIG Pressure Drop (GPM)	
			Remote Close Pneumatic	Remote Open/Close Pneumatic	Remote Open/Close Rotary	LPG	NH3
A6010	Buna-N	1 1/4" FNPT	6016-60D	6016-60C	6016RA	259	233
VA6010	Viton						
A6016	Buna-N	2" FNPT				711	640
VA6016	Viton						
A6024	Buna-N	3" FNPT				1325	1173
VA6024	Viton						

Latch Assembly for 6010, 6016 and 6024 is part #6016TFA.

Flanged Swing-Check ESVs for Bulk Plants

Part no.	Seat	Inlet & Outlet Connections	Accessories			Liquid Flow @ 10 PSIG Pressure Drop (GPM)	
			Remote Close Pneumatic	Remote Open/Close Pneumatic	Remote Open/Close Rotary	LPG	NH3
FA6010	Buna-N	1 1/4" - 300# ANSI RF Flange	FA6016-60D	-	6016RA	259	233
FVA6010	Viton						
FA6016	Buna-N	2" - 300# ANSI RF Flange		6016-60C		711	640
FVA6016	Viton						
FA6024	Buna-N	3" - 300# ANSI RF Flange		1325		1173	
FVA6024	Viton						

ROTARY ACTUATOR KIT FOR ESVS

Designed for use on 6010/6016/6024 AA Series ESVs. Features: Easy Installation, Compact design. Factory preset for open/close operation. No field adjustment required. Operates on compressed air or nitrogen. Operating pressure range 25 -125 PSIG. Thermal fuse included

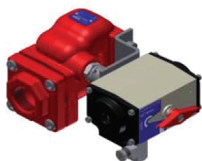

Part no.	For Use On
6016RA	6010/AA6010 6016/AA6016 6024/AA6024

REMOTE CABLE CLOSURE KIT FOR ESVS

Designed for manual remote shutdown of RegO 6010, AA6010, 6016, AA6016, 6024, AA6024 Emergency Shutoff Valves. Cable arrangement can easily be adapted for specific installation requirements.

Kit allows for remote shutoff up to 50 feet from Emergency Shutoff Valve.

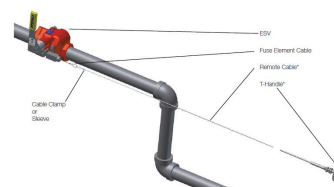

Part no.	For Use On
6016RM	6010/AA6010 6016/AA6016 6024/AA6024

6016RM Kit includes:
Cable (50'), Cable Clamps (2), Sign, Installation Instructions



Non-stock/special order items are not cancellable or returnable

Shop online at www.raymurray.com or call **800-628-5044**

Miscellaneous Equipment



ESV PNEUMATIC CONTROLS

Part no.	Description
7781AFPN-1	Cylinder assembly kit to convert 7781AF ESVs to pneumatic shutdown.
7605APN-1	Cylinder assembly kit to convert 7605B ESVs to pneumatic shutdown.
6016PN-50	Pneumatic remote shutdown system kit, complete with 100' of tubing, fittings, emergency valve and charging valve.
6016PN-80	Pneumatic Bypass Kit. Includes Tubing, tubing tee, union w/orifice, installation diagram
6016-60C	Pneumatic Remote Release Kit for use with 6010, 6016 and 6024. Open and close.
6016-60D	Pneumatic Remote Release Kit for use with 6010, 6016 and 6024. Close only.
7605A-BT	100' roll of 1/4" pneumatic tubing
7605AP-16	1/4" tubing tee with nuts
7605AP-15	1/8" NPT x 1/4" tubing, straight connector
6016RM	Remote Close Cable Kit



6016-60C



6016-60D

ESV REMOTE CABLE CONTROLS

Part no.	Description
7609-50	Transfer hose cable release kit. Attaches to ESV and hose for automatic closing as hose stretches.
7606RM	Remote manual cable release kit. Permits manual closing of one or more ESVs from remote location.
7606RT	Remote thermal cable release kit. Provides high temperature closing of ESV. Required if ESV is more than 5 feet from nearest end of hose.
7606RM-1	100' roll of extra cable.
A3219-34	Replacement fusible link for 7606RT.

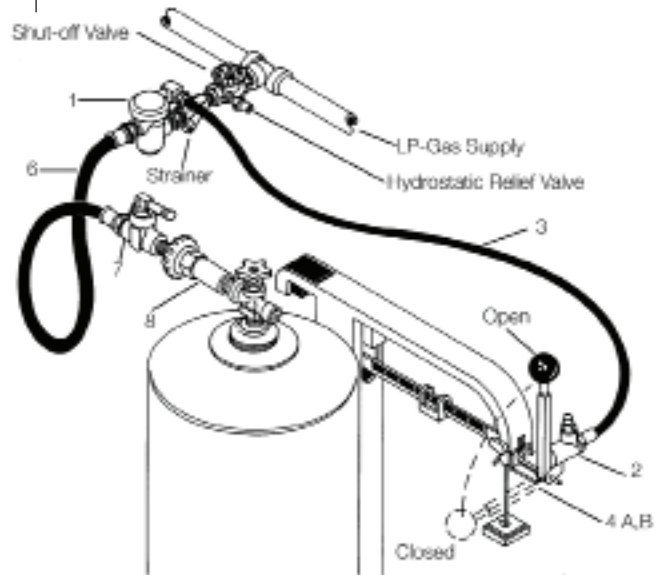

HYDRAULIC AUTOMATIC CYLINDER FILLING SYSTEM

Designed to provide accurate, economical filling of LP-Gas DOT and forklift cylinders by weight. Filling stops automatically as the total weight of the cylinder reaches the amount pre-set on the scale. One individual can efficiently handle up to four cylinder filling operations simultaneously, to maximize profits, increase efficiency and allow servicing of more customers.

Key No.	Description	Size	Part no.
Assembly for Fairbanks-Morse. Includes items 1-8 below.			7194MD
Assembly for Howe. Includes items 1-8 below.			7194HD
1	Propane control Valve	1/2" NPT Female, with 1/8" NPT Female hydraulic connection	7177
2	Master cylinder, with actuator lever	1/8" NPT hydraulic connection	7188
3	Hydraulic hose assembly	3/16" I.D. with 1/8" NPT Male ends, 43 1/2" overall length	7194-1
1-3	Valve, cylinder and hose assembly for Fairbanks-Morse scales	—	7188MS
1-3	Valve, cylinder and hose assembly for Howe scales	—	7188HS
4A	Bracket Kit for Fairbanks— Morse scales, complete with screws, washers, nuts and instructions	—	7194M-3A
4B	Bracket kit for Howe scales, complete with screws, washers, nuts and instructions	—	7194H-3
5	Can of hydraulic fluid, complete with filling spout	1 1/2 oz	7188-21
6	Propane filling hose assembly	1/2" I.D. with 1/2" NPT Male ends. 50 1/2" overall length	7193-4
7	Quick-acting shut-off valve	1/2" NPT inlet x 1/4" NPT outlet	7901TB
8*	Soft nose cylinder connector	1/4" NPT Male x POL Male	7193D-10L



Non-stock/special order items are not cancellable or returnable

Shop online at www.raymurray.com or call **800-628-5044**

Miscellaneous Equipment

LOW EMISSION HOSE END ADAPTERS FOR DOT CYLINDER FILLING

Low Emission Adapter (1.18 cc at disconnect) designed to provide quick and easy filling of DOT cylinders with minimal release of product on disconnect. This adapter may be used with dispensing systems in conjunction with RegO 7901T Series Quick Acting Shut-Off Valve. Balanced, light weight design for filling into 20 # - 200 # cylinders. Redundant Safety Feature - Will only open when connected to valve. Meets California Air Resources Board (CARB) Low Emission Standards.

7193D-10L

Part no.	Application	Inlet Connection	Outlet Connection	Materials
7193D-10L	Filling of DOT cylinders with POL Connections	1/4" MNPT	M. POL (CGA 510)	Brass & Stainless Steel
7193U-10L	Filling of DOT cylinders with Type 1 Connections	1/4" MNPT	Type 1 Connection (15/16" F. ACME)	Brass



7193U-10L

HOSE END ADAPTERS FOR DOT CYLINDER FILLING

Designed to provide quick and easy filling of DOT cylinders with POL or Type I connections. This adapter may be used with hydraulic and electric automatic systems or with manual systems in conjunction with a RegO® 7901TB Quick Acting Shut-Off Valve. These filling connectors have an extended connection on the handwheel, which makes it possible to connect the loading hose to valves on cylinders with fixed collars. The handwheel is well outside the collar for easy operation.

Part no.	Application	Inlet Connection	Outlet Connection	Materials
7193D-10	Filling of DOT Cylinders with POL Connections	1/4" M. NPT	M. POL (CGA 510)	Brass and Stainless Steel
7193U-10	Filling of DOT Cylinders with Type 1 Connections		Type 1 Connection (1 5/16" M. ACME)	Brass

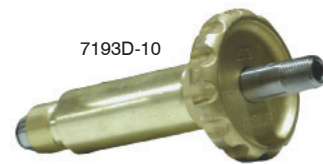

7193D-10



7193U-10

CONNECTOR FOR DOT CYLINDER FILLING ADAPTER

The 7193T-10 is designed for use on the 7193D-10 Filling Adapters. Connector allows adapter to be used on the 1 5/16 M. ACME & F. POL connections of Type 1 valves.

Part no.	Application	Inlet Connection	Outlet Connection	Materials
7193T-10	Converts 7193D-10 Adapter from POL to Type 1 Connection	F. POL (CGA 510)	Type 1 Connection (1 5/16" M. ACME)	Brass



7193T-10

HOSE END ADAPTER FOR LIFT TRUCK CYLINDER FILLING

The 7193L-10A is designed to provide quick and easy attachment of the filling hose to DOT cylinders equipped with RegO® 7141M check connectors.

Part no.	Application	Inlet Connection	Outlet Connection	Materials	Adapter
7193L-10A	Filling of Fork Lift Cylinders*	1/4" M. NPT	1 1/4" F. ACME	Brass	5760A



7193L-10A

* The 7193L-10A is intended to be permanently attached to the filling hose. A 5760A adapter enables the 7193L-10A to be attached to the POL connection on the 7193D-10 at regular cylinder filling stations to allow for occasional filling of forklift cylinders.



Miscellaneous Equipment



VENT VALVES

Especially designed to bleed off liquid or vapor pressures trapped in transfer lines. When installed in the downstream boss of Rego® globe and angle valves used at the end of a liquid transfer hose, the bleeder valve allows for the controlled venting of the product and indicates to the operator that the valves are closed and the coupling can be disconnected. They may also be used as a fixed liquid level gauge where the dip tube is part of the container.

Part no.	Service	Connection	Actuation	Warning Plate Kit
3165C	LP-Gas Only #54 Drill Orifice	1/4" M. NPT	Knurled	2550-40P
3165CP				Plate Attached
3165SC			Slotted	2550-40P
TSS3169	Tee Handle			
3165D			LP-Gas Only 3165D Series includes #72 Drill Orifice	
3165DF05.6*				
3165DF12.0*				
3165DP	Plate Attached			



*3165DF05.6 includes 5.6 dip tube. 3165DF12.0 includes 12.0 dip tube.
Note: 3162C Series Seats can be found on page A61.

FIXED LIQUID LEVEL GAUGES

Especially designed to provide a visible warning when containers are filled to the maximum permitted filling level. At the start of the filling operation, with the vent stem opened, the valve discharges vapor. When the maximum permitted filling level is reached, the valve discharges liquid. These valves are normally furnished with a 12", 3/16" O.D. dip tube and incorporate a No. 54 drill size orifice. An optional instruction plate with "Stop Filling When Liquid Appears" may be ordered for use with these valves.

Part no.	Service	Connection	Actuation	Dip Tube Length	Warning Plate Kit
3165CF	LP-Gas Only	1/4" M. NPT	Ribbed	*	2550-40P
3165DF					
3165CF12.0					
3165DF12.0			12"		
3165SFC12.0				Slotted	
TA3169F12.0	LP-Gas & NH ₃	Tee Handle			

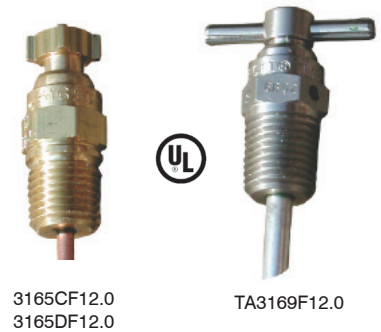

* Dip tube must be ordered separately. Add suffix. Example: 3165CF with 11" Dip Tube = 3165CF11.0.

SPANNER WRENCH FOR ACME CONNECTORS

This aluminum spanner wrench is especially designed for use with 2" and 3" ACME couplings, adapters and caps.

Part no.	For Use with ACME Connector Size
3195-50	2 1/4" & 3 1/4"



Miscellaneous Equipment

COMBINATION VALVE FOR BULK STORAGE CONTAINERS

Designed for installation on bulk storage containers, this valve combines a pressure gauge mounting and provision for a fixed tube liquid level gauge. The shut-off valve prevents the pressure gauge from being subjected to constant pressure, thereby prolonging its life and accuracy. The valve may be closed, and the vent valve opened to vent pressure from the gauge to permit replacement. For fixed liquid level gauging, the valve can be mounted at the maximum permitted filling level. When equipped with a dip tube threaded 1/8" M.NPT, it can be installed at any convenient level.

Part no.	Container Connection	Service Connection	Liquid Level Vent
A2805C	3/4" M. NPT	1/4" F. NPT for Gauge Mounting	Knurled*

A2805C



* Has 1/8" F. NPT opening for installing separate dip tube.

GRITROL FUEL LINE FILTERS

Designed especially for use in liquid Autogas lines to trap foreign material which otherwise may damage precision components in the LP-Gas carburetion system. These filters incorporate an integral sintered metal filter element in a straight through design.

Part no.	Inlet Connection	Outlet Connection
12802	1/4" F. NPT	1/4" M. NPT



12802

PRESSURE GAUGES

Especially designed in a variety of sizes and construction for the LP-Gas and anhydrous ammonia industry. All RegO® pressure gauges have a 1/4" M. NPT connection unless otherwise noted.



5575

Part no.	Service	Case Material	Maximum Pressure	Case Size	Increment Divisions
2434A-2*	LP-Gas Only	Steel	35" w.c. and 20 oz. (Dual)	2 1/2"	1" w.c. and 1 oz.
2434-2**					
3226A-3		Brass	30 PSIG	2"	1/2 PSI
2411					
5575		Steel	60 PSIG	2"	1 PSI
5547					
5576		Brass	100 PSIG	2"	2 PSI
1286					
948		Brass	300 PSIG	2"	5 PSI
948B					
A8060	NH ₃ & LP-Gas	Steel	60 PSIG	2 1/2"	5 lb.
A8150			150 PSIG		
A8400			400 PSIG		

* 1/4" Hose Connection. ** 1/8" M. NPT Connection

NEEDLE VALVES

These valves are high quality, "true" throttling valves. Unlike most so-called needle valves, both the body seat and stem are tapered to provide fine, precise control over a wide range of adjustment without stem galling. The 1224 may be used as a small, inexpensive shut-off valve between a pressure gauge and bulk storage container to allow for convenient gauge replacement. The 1316 and 1318 provide taper pipe thread by left hand hose connection threads and are useful in a wide range of torch and fuel burner applications where an accurate throttling action is required.

Part no.	Inlet Connection	Outlet Connection	Height	Length
1224WA	1/4" M. NPT	1/4" M. NPT	1 9/16"	1 3/4"
1316WA	9/16" - 18 L.H.	1/8" M. NPT		
1318WA		1/4" M. NPT		

1224WA

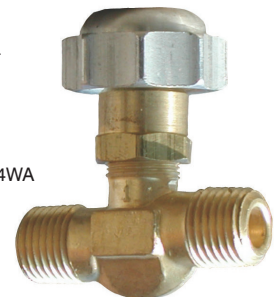

Non-stock/special order items are not cancellable or returnable

Shop online at www.raymurray.com or call **800-628-5044**

Buna-N O-Rings & Gaskets



BUNA-N O-RINGS AND GASKETS (ACTUAL SIZE)

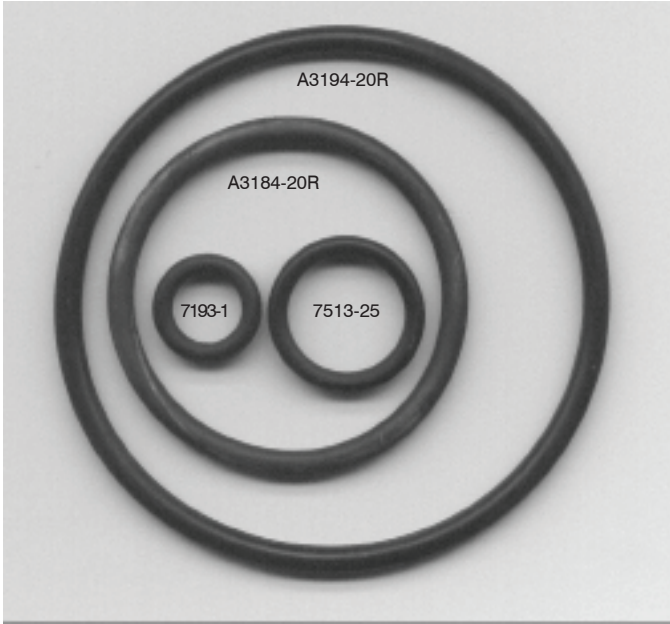

Buna-N O-Rings

Part no.	Use	Size	Qty. in Package
7193-1	POL Nipple	POL	1
7513-25	Internal Fork Lift	1¼" ACME	1
A3184-20R	Filter, Vapor Valve and Adapter Connections	2¼" ACME	10
A3194-20R		3¼" ACME	10

Gaskets

Part no.	Use	Size	Qty. in Package
7141M-3R	Fork Lift Connector	1¼" ACME	25
A2797-20R	Filter, Vapor Valve and Adapter Connections	1¼" ACME	25
A2697-20R		1¾" ACME	25
A3184-8R		2¼" ACME	10
A3194-8R		3¼" ACME	10

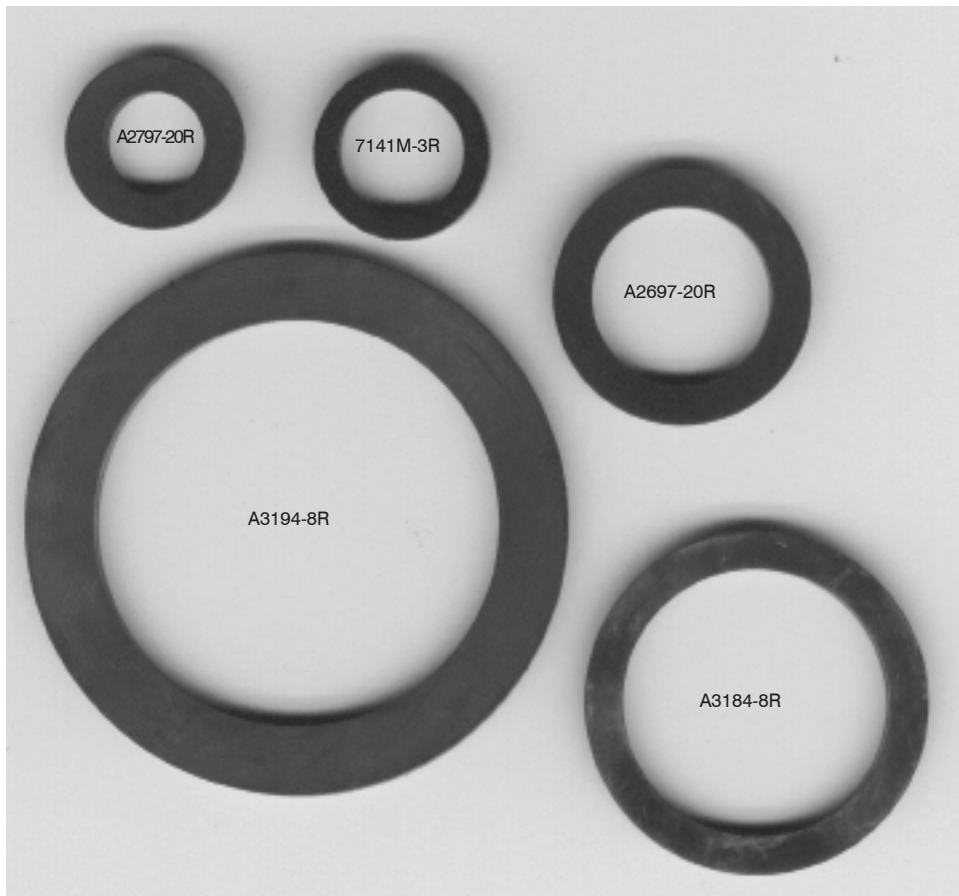

Non-stock/special order items are not cancellable or returnable

Shop online at www.raymurray.com or call **800-628-5044**

Repair Kits & Assemblies

MULTIVALVES - BONNET ASSEMBLIES

Part no.	Kit no.	Kit Contents
6532D Ser.	903-50	Bonnet: stem and seat disc assembly; large handwheel; self-tapping screw
6533D Ser.		
6542D Ser.	903-51	Bonnet: stem and seat disc assembly; small handwheel; self-tapping screw
6543D Ser.		
6532A Ser.	19100-50B	Bonnet: stem and o-ring assembly; handwheel; self-tapping screw
6533A Ser.		
6542A Ser.		
6543A Ser.		
6555D Ser.	19104-50	Complete MultiBonnet assembly-bonnet assembly; handwheel; nameplate; self-tapping screw
7556V Ser.		
8555D Ser.		
8555DL Ser.		
6532R Ser.		
6533R Ser.		
6542R Ser.		
6543R Ser.		
6555R Ser.		
7556R Ser.		
G8475R Ser.		
8593AL16.0		
9101R Ser.		

CHARGING MANIFOLDS

Part no.	Kit no.	Kit Contents
7177 Control Valve	7177-50	Diaphragm; gasket; o-ring; seat disc; washer
7188 Master Cylinder	7188-50	Hydraulic fluid; o-rings; piston; spring; trip latch

DUOPOINT & MULTIPOINT RELIEF VALVE MANIFOLDS

Part no.	Kit no.	Kit Contents
8542G	8540-50	Bleeder valve assemblies; packing gland; set screw; washer; gasket; key
AA8542 Ser.		
A/AA8560 Ser.	8560-50	Bleeder valve assemblies; seat ring assemblies; pressure seal rings; packing gland; jam ring; washer; gasket
A/AA8570 Ser.		

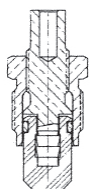

903-50



19100-50B

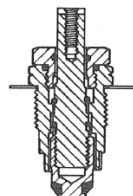

19104-50

CHECK CONNECTORS

Part no.	Kit no.	Kit Contents
7141M	7141M-50	Check assembly; gasket; o-ring; retaining ring

CYLINDER AND SERVICE VALVES

Part no.	Kit no.	Kit Contents
901 Ser. 903 Ser. 9106CO	903-50	Bonnet; stem and disc assembly; large handwheel; self-tapping screw
	903-51	Bonnet; stem and disc assembly; small handwheel; self-tapping screw
9101 Ser.	19100-50B	Bonnet; stem and seat disc assembly; small handwheel; self-tapping screw
9107K8A	19104-50	Complete MultiBonnet assembly-bonnet assembly; handwheel; nameplate; self-tapping screw
3100 Series (Obsolete) 7100 Series (Obsolete)	3100-81K	Bonnet and stem assembly; gasket (Conversion Assembly)
	Conversion Kit	
	3100-80A	Diaphragm; bonnet and stem assembly
	3100-80B	Diaphragm assembly; back seat; washer
9101P5, P5H	19100-50B	Bonnet; stem and seat disc assembly; large handwheel; self-tapping screw
	19101-50	Bonnet; stem and seat disc assembly; small handwheel; self-tapping screw

FILLER VALVES

Part no.	Kit no.	Kit Contents
7547 Ser. (Obsolete)	7547B-80	Gaskets; spring; seat disc and retainer assembly
L7579	L7579-50	Gaskets; seat disc and retainer assembly; spring; upper body
	with upper body	
	L7579-80	Gaskets; seat disc and retainer assembly; spring
	w/out upper body	
7647 Ser.	7647B-80A	Gaskets; spring; seat disc and retainer assembly

Note: L7579 is Low Emission. For the old style 7579, use repair kits 7579-50 and 7579-80.

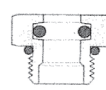

19104-80

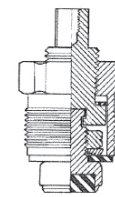

3100-80A

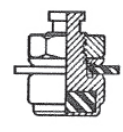

3100-80B



Non-stock/special order items are not cancellable or returnable

Shop online at www.raymurray.com or call **800-628-5044**

Repair Kits & Assemblies



MULTIVALVES - VAPOR EQUALIZING

Part no.	Kit no.	Kit Contents
7556V Ser. G8475 Ser. 8593AR16.0	8475-51A	Body; gaskets; spring; stem and seat disc assembly
	8475-81A	Gaskets; spring; stem and seat disc assembly

TRANSFER VALVES

Part no.	Kit no.	Kit Contents
7550P 7550PX 7555P	7550-15	Bonnet; retainer assembly; cap; flange packing; bushing
A7550P A7550PX A7555P	A7550-15	Bonnet; stem; seat disc retainer assembly; flange packing; bushing; cap

MULTI-PURPOSE AND TRANSFER VALVES

Part no.	Kit no.	Kit Contents
A8016D Ser. A8017D Ser. A8018D Ser.	A8016B-50	Gaskets; jam ring; o-ring; pressure seal rings; seat disc; washer
A8017DH A8018DH	A8017BH-20R	Bonnet stem and seat disc assembly; gasket

PULL-AWAY COUPLINGS

Part no.	Kit no.	Kit Contents
A2141A6 A2141A6L	A2141A6-50	O-ring
	A2141A6M	Male Coupling
A2141A8 A2141A8L	A2141A8-50	O-ring
	A2141A8M	Male Coupling
A2141A10	A2141A10-50	O-ring
A2141A16	A2141A16-50	O-ring

MULTIVALVES - FILLER VALVES

Part no.	Kit no.	Kit Contents
6532 Ser. 6533 Ser. 6542 Ser. 6543 Ser. 85855 Ser. (mfd; Oct 1990 or before) 8555DL Ser.	6542B-50	Gaskets; spring; spring guide; stem and seat disc assembly; upper body
	with upper body	
	6542B-80	Gaskets; spring; spring guide; stem and seat disc assembly
w/out upper body		
6555 Ser. 8555 Ser. (mfd. after Oct 1990)	8555-50	Gaskets; spring; spring guide; stem and seat disc assembly; upper body
	with upper body	
G8475 Ser. 8596AR16.0	8475-50L	Gaskets; seat disc and retainer assembly; spring; upper body
	with upper body	
	8475-80	Gaskets; seat disc and retainer assembly; spring
	w/out upper body	

MANUAL INTERNAL VALVES

Part no.	Kit no.	Kit Contents
A3209A	A3209A-50	Bearing; cam; gasket; main seat disc assembly; retaining ring; seal o-ring; seat disc
A3209R050 A3209R080	A3209R-50	
A3212R Ser. A3212RT Ser.	A3212R-50	Bearing; cam; gasket; o-rings; seat disc; stem packing
A3219FA	A3219FA-80G	Bumper; cotter pins (3); dirt seal; inner and outer stem bearing; lever release spring; main seat disc; poppet seat disc; pivot pin locknut; poppet bearing; seal gland gasket; seat seal o-ring; stem jam ring; stem seal rings (3); stop screw; upper and lower flange seal o-ring

MULTI-PORT SPARE FLANGE GASKETS

Part no.	Description
7564-48	Flange gasket for use in 8560 Series 3" MultiPorts
7565-48	Flange gasket for use in 8570 Series 4" MultiPorts

Repair kits are available for many RegO obsoleted products. Call with your specific application.



Non-stock/special order items are not cancellable or returnable

Shop online at www.raymurray.com or call **800-628-5044**

Repair Kits & Assemblies

GLOBE VALVES

Part no.	Kit no.	Kit Contents
TA7034LP TA7034P	TA7034-50	Gaskets; jam ring; o-ring; pressure seal rings; seat disc; washer
A7505AP A7506AP	A7505-50 7505A-20	Complete bonnet assembly
TA7507AP TA7508AP	A7507-50 A7507A-20	Gaskets; jam ring; o-ring; pressure seal rings; seat disc; washer Complete bonnet assembly
A7509BP A7510BP	A7509-50 7509B-20	Gaskets; jam ring; o-ring; pressure seal rings; seat disc; washer Complete bonnet assembly
TA7509BP TA7510BP	TA7509B-50	Gaskets; jam ring; o-ring; pressure seal rings; seat disc; washer
A7511AP A7511FP A7512AP A7512FP	A7511-50 7511A-20	Gaskets; jam ring; o-ring; pressure seal rings; seat disc; washer Complete bonnet assembly
TA7511AP TA7511FP TA7512AP TA7512FP	TA7511A-50	Gaskets; jam ring; o-ring; pressure seal rings; seat disc; washer
A7513AP A7513FP A7514AP A7514FP	A7513-50	Gaskets; jam ring; o-ring; pressure seal rings; seat disc; washer
A7513AP A7514AP A7513FP	7513A-20 A7513F-20	Complete bonnet assembly
TA7513AP TA7513FP TA7514AP TA7514FP	TA7513A-50	Gaskets; jam ring; o-ring; pressure seal rings; seat disc; washer
A7517AP A7517FP A7518AP A7518FP	A7515-50 A7515-20	Gaskets; jam ring; o-ring; pressure seal rings; roll pin; seat disc; washers Complete bonnet assembly
TA7517AP TA7517FP TA7518AP TA7518FP	TA7515A-50	Gaskets; jam ring; o-ring; pressure seal rings; roll pin; seat disc; washers
A7704 A7705 A7706	A7705-50	Flange packing; friction washer; gaskets; seat disc
TA7894P	TA7894-50	Gaskets; jam ring; o-ring; pressure seal rings; seat disc; washer

VAPOR RETURN VALVES

Part no.	Kit no.	Kit Contents
7573A	7573A-81	Gaskets; spring; seat disc and retainer assembly
7573D	7573D-81	Gaskets; spring; seat disc and retainer assembly

QUICK ACTING HOSE END VALVES

Part no.	Kit no.	Kit Contents
A7707 Ser. A7708 Ser.	A7707-50 A7707-75	Gaskets; groove pin; jam ring Bonnet assembly; packing; seat disc and retainer; stem; washers

QUICK ACTING VALVES

Part no.	Kit no.	Kit Contents
7554L Ser. 7554S Ser.	7554L-20A 7554S-20	Bonnet Assembly
7901 Ser.	7901T-50	Bonnet Assembly w/double o-ring seal; gasket; lever
A7553A	A7553A-50	Gaskets; o-ring; roll pin; seat disc; spring; stem assembly
A7797A	A7797-50	Gaskets; groove pin; jam ring; o-ring; pressure seal rings; seat disc; washers

SPRING KITS FOR MANUAL INTERNAL VALVES

Part no.	Kit no.	Kit Contents
A3212A Ser. A3212R Ser. A3212RT Ser.	A3212R-K105 A3212R-K175 A3212R-K250	O-ring; ID plate; spring
A3213A Ser. A3213T Ser.	A3213A-K150 A3213A-K200 A3213A-K300 A3213A-K400	

FLOMATIC VALVES

Part no.	Kit no.	Kit Contents
A7884 A7883F A7884F	A7883F-50	Stem assembly kit; bleeder assembly; cylinder cap screws; upper and lower piston cap screws; lock washers; filters; springs; block vee packing; x-seal; gaskets; o-rings; retaining ring; insert roll pin; screw seal; cap
A7883F	A7883F-80	Retaining ring; seat disc; insert; block vee packing; filters; x-seals; cylinder cap screws; o-rings; gaskets
A7883F A7884F	A7883F-150 A7884F-150	X-seal; seat disc; gaskets

DISC SEAT AND STEM ASSEMBLIES

Part no.	Description
3162C-6	Nitrile seat ,no star stamp
3162C-6D	Nitrile seat, star stamp on top
3162C-6V	Viton Seat Material



Non-stock/special order items are not cancellable or returnable

 Shop online at www.raymurray.com or call **800-628-5044**

Repair Kits & Assemblies



Part no.	Description
404PE	Pipe Away Kit
903-50	Repair Assembly
903-51	Repair Assembly
1475-80	Repair Kit
A2141A10-50	Repair Kit
A2141A16-50	Repair Kit
A2141A6-50	Repair Kit
A2141A6M	Repair Kit
A2141A8-50	Repair Kit
A2141A8M	Repair Kit
2550-40P	Nameplate-Warning
A2697-20R	Gaskets (25)
A2797-20R	Gaskets (25)
3100-80A	Repair Kit
3100-80B	Repair Kit
3100-81K	Stem Assembly Kit
A3184-20R	O-rings (10)
A3184-8R	Gaskets (10)
A3194-20R	O-rings (10)
A3194-8R	Gaskets (10)
A3209A-50	Repair Kit
A3209R-50	Repair Kit
A3212A-80	Repair Kit
A3212R-K105	Spring Kit
A3212R-K175	Spring Kit
A3212R-K250	Spring Kit
A3213A-K150	Spring Kit
A3213A-K200	Spring Kit
A3213A-K300	Spring Kit
A3213A-K400	Spring Kit
A3213A-80	Repair Kit
6016PN-3	Pressure Gauge
6016PN-50	Remote Pneumatic Control Kit
6016PN-80	Pneumatic Bypass Kit
6542B-50	Repair Assembly
6542B-80	Repair Assembly
7141M-3R	Gaskets (25)
7141M-50	Repair Kit
7177-50	Repair Kit
7188-50	Repair Kit
7505A-20	Bonnet Assembly
A7505-50	Repair Kit
7505A-4	Seat Disc
A7507-50	Repair Kit
7505A-4	Seat Disc
7509A-5	Seat Disc Retainer Assembly
7509B-20	Bonnet Assembly
A7509-50	Repair Kit
A7509A-50	Repair Kit
TA7509B-50	Repair Kit
7511A-20	Bonnet Assembly
A7511-50	Repair Kit

Part no.	Description
TA7511A-50	Repair Kit
7513A-20	Bonnet Assembly
A7513-50	Repair Kit
A7513F-5TX	Seat Disc Retainer Assembly
TA7513A-50	Repair Kit
A7515-4	Seat Disc
A7515-5	Seat Disc Retainer Assembly
A7515-20	Bonnet Assembly
A7515-50	Repair Kit
TA7515A-50	Repair Kit
7547B-80	Repair Kit
A7550-5	Seat Disc Retainer Assembly
7553T-50	Bonnet Assembly
7553T-80	Repair Kit
A7553A-50	Repair Kit
7554-20	Bonnet Assembly
7554A-20	Bonnet Assembly
7554S-20	Bonnet Assembly
L7579-50	Repair Kit
L7579-80	Repair Kit
7609-50	Transfer Cable Kit
A7705-50	Repair Kit
A7707-50	Repair Kit
A7797-10M	Handle Assembly
A7797-50	Repair Kit
A7797-75	Stem, Bonnet and Lever Asm Kit
A7797A-4	Stem and Bonnet
A7853A-50	Repair Kit
A7883F-150	Kit
A7883F-45	Stem Assembly Kit
A7883F-50	Kit
A7883F-80	Flomatic Valve Kit
A7884-60	Pump Prime Valve Assembly
A7884F-150	Repair Kit
TA7894-50	Repair Kit
7901T-50	Bonnet Assembly
A8016B-50	Repair Kit
A8017BH-20R	Repair Kit
8100-50	Repair Kit
8475-50L	Repair Kit
8475-51A	Valve Repair Kit
8475-80	Repair Kit
8475-81A	Repair Kit
8540-50	Repair Kit - Duoport
8555-50	Repair Kit
8560-16TK	Seat Ring Assembly
8560-50	Multiport Repair Kit
19100-50B	Repair Assembly
19101-50	Repair Kit
19104-50	Repair Assembly
19104-80	Repair Assembly



Non-stock/special order items are not cancellable or returnable

Shop online at www.raymurray.com or call **800-628-5044**